









STONEX R20  
Total Station  
**User Manual**



## Contents

1.	Introduction.....	5
2.	Precautions for safety .....	6
2.1.	Laser damage.....	6
2.2.	Glare damage .....	7
2.3.	Fire risk.....	7
2.4.	Electric shock risk .....	7
2.5.	EMC .....	8
2.6.	Mechanical injury .....	8
2.7.	Other safety items.....	9
2.8.	General Notes.....	9
2.9.	Disclaimer.....	9
3.	Nomenclature .....	11
3.1.	Important Parts .....	11
3.2.	Technical Terms and Abbreviations .....	12
3.3.	Keypad.....	13
4.	Preparation & Setting up .....	15
4.1.	Battery and Charger .....	15
4.2.	Power on / off.....	16
4.3.	Setting / Leveling up and Centring .....	17
4.4.	Tilt Compensation.....	18
4.5.	Touch Trigger Key.....	20
4.6.	Display & Main Menu.....	20
4.7.	Quick Functions .....	21
4.8.	Edit.....	22
4.9.	Focusing and Collimating .....	23
5.	Measurement.....	24
5.1.	Measurement Interface.....	24
5.2.	Angle Measurement.....	26
5.3.	Distance Measurement .....	29
5.4.	Coordinates Measurement.....	30

6. Survey		31
6.1. Surveying		33
6.2. Stake Out		35
7. Applications		38
7.1. Offset		38
7.2. Missing Line Measurement		42
7.3. Remote Height		44
7.4. Area		45
7.5. Resection		46
7.6. Reference Line		48
8. File Management		53
8.1. Job Management		53
8.2. Measurement Data		53
8.3. Fixed Points		54
8.4. Codes		55
8.5. Data Transfer		55
8.6. Data Delete		57
8.7. Memory Statistic		58
9. Instrument Settings		59
9.1. Unit Settings		59
9.2. Angle Settings		60
9.3. Default Interface		60
9.4. EDM Settings		61
9.5. Date and Time Setting		63
9.6. Shortcut Keys		63
9.7. Other Settings		63
9.8. Restore Factory		64
10. System Information		65

10.1.	Instrument Information .....	65
10.2.	System Upgrade.....	65
11.	Data Transfer and Formats.....	67
11.1.	Bluetooth .....	67
11.2.	USB Stick.....	68
11.3.	Data conversion .....	68
12.	Calibration  .....	69
12.1.	About Calibration .....	69
12.2.	HZ-collimation and V-index .....	69
12.3.	Program Calibration .....	70
12.4.	Mechanical Check and Adjust.....	72
13.	Technical Data.....	74
13.1.	Angle measurement .....	74
13.2.	Distance measurement.....	74
13.3.	General data .....	75
14.	Kit components .....	77
15.	Care and Transport.....	78
15.1.	Storage .....	78
15.2.	Transport.....	78
15.3.	Cleaning and Drying.....	79
16.	Appendix.....	80
16.1.	Atmospheric Correction.....	80
16.2.	Refraction and Earth Curvature Correction.....	81
	Limited warranty standard .....	82
	General warranty for instruments.....	82
	Shipping policy .....	82
	Return policy dead on arrival instruments .....	82
	Firmware/Software warranty.....	83
	Over warranty repair(s) policy.....	83
	Disclaimer and limitation of remedy .....	83
	Instrument warranty.....	83

Environmental recycling.....84

## 1. Introduction

Thank you for purchasing R20 total station from STONEX.

This manual includes important safety directions and instructions for setting up and using the product.

Please read this manual carefully before using, so that our products can serve you better.

When you begin to use the product, we assume that you are a competent user who has read through and understood the contents of this manual and is fully aware of the necessary dangers, warnings and cautions.

In the event of any discrepancy between the information contained in this manual and the actual, the actual information shall prevail, and the Company reserves the right to make further revisions or changes to this manual without notice.

### **Basic operating instructions:**

- This product must be operated by professional. The user must be a professional measurer or a person with equivalent knowledge of measurement in order to be able to accurately understand this user manual and the relevant safety instructions and to use, check and calibrate the instrument correctly.
- Always use the instrument in a safe environment and wear the necessary safety equipment (e.g., helmet, reflective vest, safety shoes, etc.) properly.

### **The scope of using this instrument:**

- Operate instruments to observe, indicate, or direct the displacement of a specific target.
- Measure horizontal and vertical angles.
- Measure the distance to a specific target.
- Record, store and edit measurement data.
- Calculate data using built-in applications.
- Data exchange using USB storage devices.
- Communication with the instrument using Bluetooth.
- The necessary calibration.
- Other operations guided by this manual.

### **The scope of this instrument does not apply to:**

- Perform instrument operation in unsafe environments or where instrument weathering requirements are exceeded.
- Do not follow the Dangers and Warnings in the manual.
- Do not operate the instrument in accordance with the manual.
- Use the instrument beyond its capabilities.
- Adjustment, disassembly of instruments beyond what is specifically allowed.
- Repair or modification of instruments.

## 2. Precautions for safety

### 2.1. Laser damage

The instrument uses a visible red laser for distance measuring. The laser is emitted from the center of telescope objective when measuring or laser pointer is turned on.

The instrument's laser plummet uses a visible red laser to indicate the position of the vertical axis. The laser is emitted from the bottom of the instrument along the center axis during leveling and centering operations.

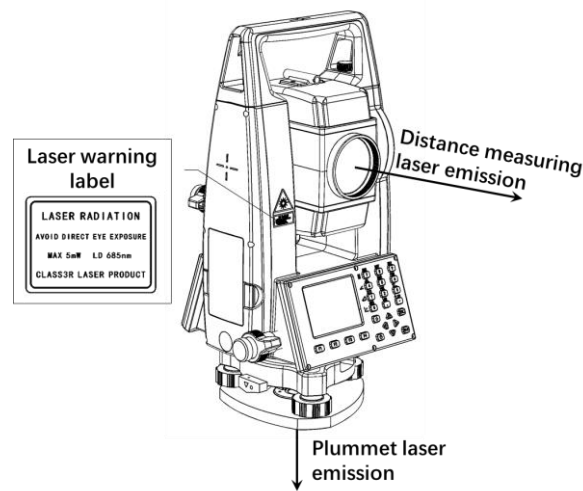

In accordance with the state of the international standard IEC 60825-1(2014-05), the product is classified as different Laser class on different working mode.

Working Mode	Laser Class
Distance measuring with reflector prism and tape	Class 1
Distance measuring without reflector	Class 3R
Laser plummet	Class 2

Direct laser beams can cause eye discomfort, temporary blindness and residual images. Prolonged exposure to laser beams can cause permanent damage to the eyes.

- Do not look directly at the laser beam at any time, and do not use optical equipment such as binoculars to view the laser beam.
- It is prohibited to direct a laser beam at another person.
- Do not stare at the spot of laser for a long time at close range.
- Avoid direct the laser at any highly reflective object that is not a reflector prism or tape, such as windows, mirrors, traffic signs, etc.
- Turn off the pointer and plummet laser as much as possible when not working on distance measuring or centering.

## 2.2. Glare damage

Looking directly at hard light can cause eye discomfort, temporary blindness and residual images, and prolonged exposure to direct bright light can cause permanent damage to the eyes.

- Viewing the sun through the instrument's telescope is prohibited at any time.
- Avoid using instruments to aim at objects that are strongly reflecting sunlight, such as mirrors, glass, water, car surfaces, etc.
- Avoid observing strong lights and other light sources.

## 2.3. Fire risk

The design and manufacture of the instrument and its accessories follow the relevant standards and directives to avoid as much as possible the danger of high temperature, fire and other dangerous conditions in normal operation. However, using the instrument under special conditions, using it irregularly and disassembling it may lead to localized high temperature, fire or even explosion.

- The use of this instrument in coal mines is prohibited.
- When there are dangerous, flammable or explosive gases or liquids in the vicinity of the workplace, it is prohibited to operate the instruments.
- Do not use the instrument in a hot environment or near flames.
- Batteries must not be placed in fire or high temperature environments.
- The battery should not be covered by any object during charging to avoid the risk of overheating and fire.
- The battery must not be disassembled.
- Avoid keys, metal objects connected to the electrodes of the battery, or the electrodes of the charger.
- Avoid the use of unqualified, faulty or damaged sockets when charging, and prohibit any operation that uses wires directly connected to the plug.
- Avoid contact of the instrument, batteries, chargers, adapters, power cables, etc. with any liquid. Avoid using, storing, or charging the instrument in a raining, dripping, or wet environment.
- Batteries shall be transported in proper packaging.
- Do not use any batteries, chargers, adapters, power cables, etc. that are not supplied by the Company.
- If any abnormality or damage is found in batteries, chargers, adapters, cables, etc., stop using them immediately and dispose of them properly.
- Keep batteries, chargers, etc. clean to avoid excessive dust accumulation.
- Do not make any modifications to the instrument, batteries, chargers, adapters, cables, etc.

## 2.4. Electric shock risk

This instrument is powered by rechargeable batteries. The charger needs to be connected to city power during the charging process, and any improper handling of electricity may result in electric shock.

- Prohibit operate near high-voltage power transmission and large power facilities.
- Whenever possible, avoid using centering rod near electrified railroads, power lines, etc.
- Outdoor work during thunderstorms is prohibited.
- Do not operate instruments, batteries, chargers, etc. with wet hands.



- Avoid keys, metal objects connected to the electrodes of the battery, or the electrodes of the charger.
- Avoid the use of unqualified, faulty or damaged sockets when charging, and prohibit any operation that uses wires directly connected to the plug.
- Avoid contact of the instrument, batteries, chargers, adapters, power cables, etc. with any liquid. Avoid using, storing, or charging the instrument in a raining, dripping, or wet environment.
- Do not use any batteries, chargers, adapters, power cables, etc. that are not supplied by the Company.
- If any abnormality or damage is found in batteries, chargers, adapters, cables, etc., stop using them immediately and dispose of them properly.
- Do not make any modifications to the instrument, batteries, chargers, adapters, cables, etc.

## 2.5. EMC

The instrument is designed and manufactured in accordance with the relevant standards for electromagnetic compatibility, but it may still cause electromagnetic interference that interacts with other electronic equipment nearby. Instrument and charger in operation may interfere with nearby sensitive electronic equipment and affect their normal operation. Strong sources of electromagnetic radiation in the nearby environment may also interfere with the instrument, causing unpredictable measurement errors, abnormal operation and, in particularly serious cases, even irreversible damage.

- Avoid using instruments in environments of strong electromagnetic interference, such as near large electrical utilities, high-power radio transmission facilities, wireless communication equipment, big electric motors, etc.
- If abnormal display, abnormal jumping of measurement data and other abnormalities are detected during operation, stop operation immediately and turn off the instrument. Continue operation only after confirming that the surrounding electromagnetic compatible environment is suitable for continued operation.

## 2.6. Mechanical injury

Instruments and tripods are heavy objects that may cause damage to people, equipment or other items if dropped, fallen or broken. Be careful when handling, using, and transporting the instruments, as they are precision instruments.

- To avoid the risk of injury from collapsing, the tripod should be set up carefully according to the instruction, and the clamping screws should be tightened after the adjustment of the tripod legs.
- The instrument must be properly fixed on the tripod and checked frequently to avoid injury from falling or damage to the equipment.
- In all cases, be aware of the possible danger posed by the sharp toe of the tripod legs. Care shall be taken when setting or handling.
- Dropping and high intensity shaking of the transport case may damage the case and the instrument.
- Do not sit or stand on the transport case, and avoid placing heavy objects on the case.
- Do not use a transport case with broken body, damaged hinges, or latches.
- Avoid strong vibrations, shocks to the instrument, tripod, transport case, etc.

## 2.7. Other safety items

- It is not permitted to use the instrument in locations where measurement operations are prohibited by law or other regulations.
- Pay attention to the safety of the surrounding environment when using the instrument to avoid accidents or equipment damage caused by traffic accidents, falling objects, collapsing buildings, ground subsidence, mechanical equipment collisions and other accidents.

## 2.8. General Notes

Before using the instrument, be sure to check and confirm that the instrument and accessories are complete and that all functions work properly.

- Do not aim the instrument at the sun.
- A qualified tripod is required to set up the instrument.
- The use of a qualified tribrach is required for the instrument. Fasten the instrument with its tribrach correctly.
- When measuring, the instrument and tribrach must be properly and solidly fixed on the top plate of tripod with the fixing screw. The clamping screws should be tightened after the adjustment of the tripod legs.
- Avoid vibration of the instrument and tripod during measurement.
- When handling instruments, avoid bumping and dropping as much as possible.
- When lifting the instrument, always grip the handle properly and make sure it is securely attached to the instrument.
- Do not leave the apparatus in a hot environment for too long, paying particular attention to environments where the temperature may be too high, such as in a car in hot weather.
- Sudden changes in the temperature of the instrument will affect the measurement accuracy. If the ambient temperature changes too much, the instrument should be left for a period to adapt to the ambient temperature before starting measurements.
- Avoid direct sunlight on the instrument during measurement, and it is recommended to use umbrellas or other shelters.
- Check the battery level to ensure sufficient operating time.
- It is recommended that you do not remove the battery while the instrument is on. Please remove and install the battery after the instrument is turned off.
- Any obstructions in the path of view between the instrument and the target to be measured during distance measurement operations may lead to erroneous measurements.
- Necessary self-check should be performed after collision, collapse, etc., as well as after long-term storage and long-distance transportation of the instrument.

## 2.9. Disclaimer

- The user of this product should have sufficient measuring skills and use it in accordance with the user manual.
- The user should carry out periodic self-check of the instrument's performance.
- The manufacturer and its agents cannot be held responsible for the consequences and loss of profit

resulting from non-compliance with these operating instructions.

- The manufacturer and its agents are not responsible for any loss of work due to changes in data, loss of data, environmental disturbances, etc.
- The manufacturer and its agents cannot be held responsible for the consequences and loss of profit due to improper handling, incorrect setting up or improper connection to other products.
- The manufacturer and its agents cannot be held responsible for any direct or indirect consequences and loss of profit resulting from intentional damage, improper use or accidental operation of the product.
- The manufacturer and its agents shall not be liable for any direct or indirect consequences and loss of profit caused by force majeure (such as earthquakes, storms, lightning, floods, fires, collapses, etc.), or by third parties.

### 3. Nomenclature

#### 3.1. Important Parts

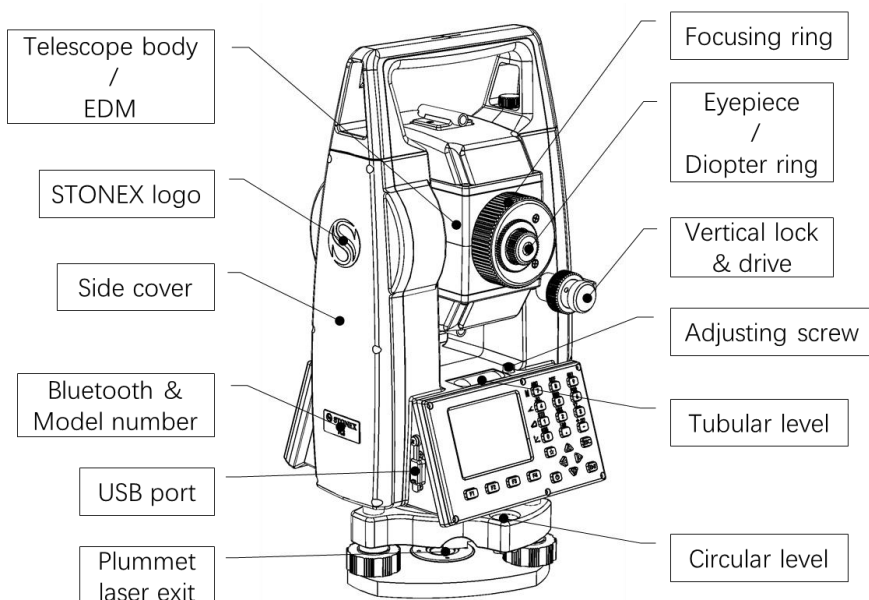
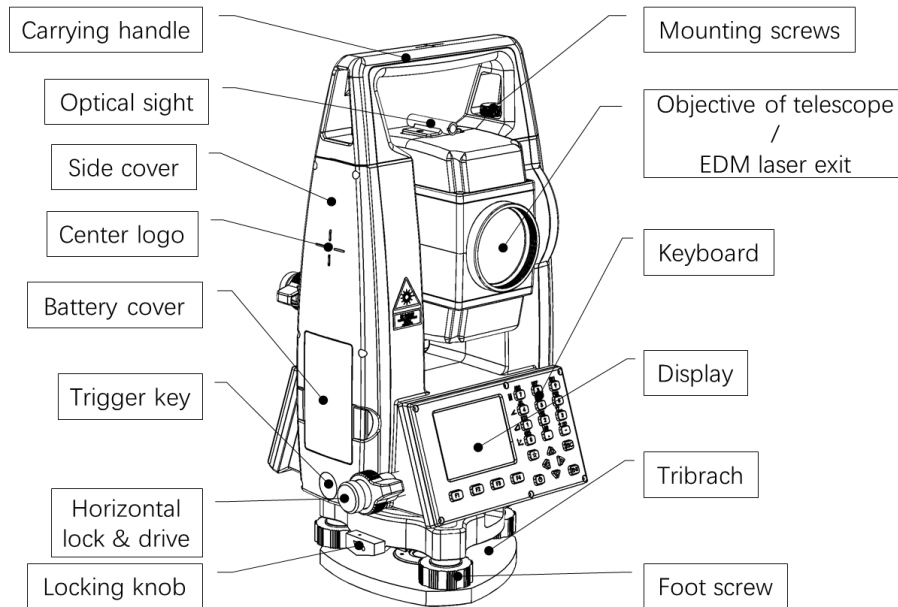

### 3.2. Technical Terms and Abbreviations

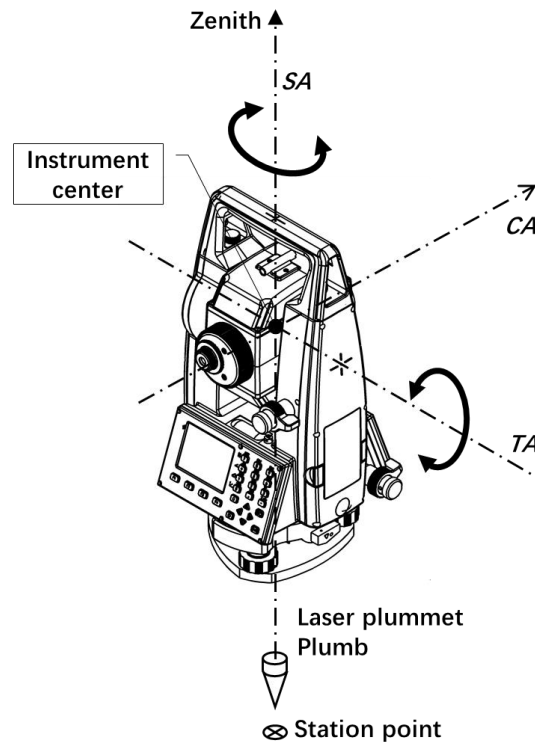

Technical terms / Abbreviations	Description
Telescope	Optical telescope for observation and aiming, also the collimated part of the Electronic Distance Meter (EDM).
Collimation Axis / CA	Line from the reticle to the centre of the objective, as well as telescope axis and EDM laser axis.
Standing Axis / SA	Vertical rotation axis of the instrument.
Tilting Axis / TA	Horizontal rotation axis of the telescope.
Instrument Center (Zero Point)	The intersecting point of CA, SA and TA, as well as the zero point of EDM.
Zenith	The top point of the direction which gravity is through the Instrument Center, as well as Plumb Line and plummet laser axis.
Zenith Angle / ZA	The angle between CA and Zenith.
Vertical Angle / VA	The angle between CA and horizontal line.

Under ideal instrumentation and set-up conditions, the following properties are desirable:

- The SA, the laser plummet axis, and the zenith/plumbline are co-linear and pass through the current station point.
- The tubular level and the circular level are perpendicular to the SA.

- The CA is coaxial with the EDM laser axis and perpendicular to the TA.
- The TA is perpendicular to the SA.
- The CA, SA and TA intersect at the instrument center.

The actual non-ideal condition, the instrument and set up will also have various errors.

By carefully setting up the instrument, double-sided observation, automatic compensation and correction, the impact of errors on measurement can be partially eliminated (refer to [Tilt Compensation](#), Symbols

The symbols and formats used in this Manual have the following meanings:

Symbols & Formats	Description
	Terminology, technical notes.
[ENT]	The keys on the instrument's keypad are indicated in [ ].
[DST]	The contents of the softkey commands displayed on the display are indicated in [ ].
<VA>	The contents of the fields displayed in the function area of the display are indicated in < > .
{Surveying}	The name of the current application, menu, or step in the status bar of the display interface is indicated in { } .

### 3.3. Keypad

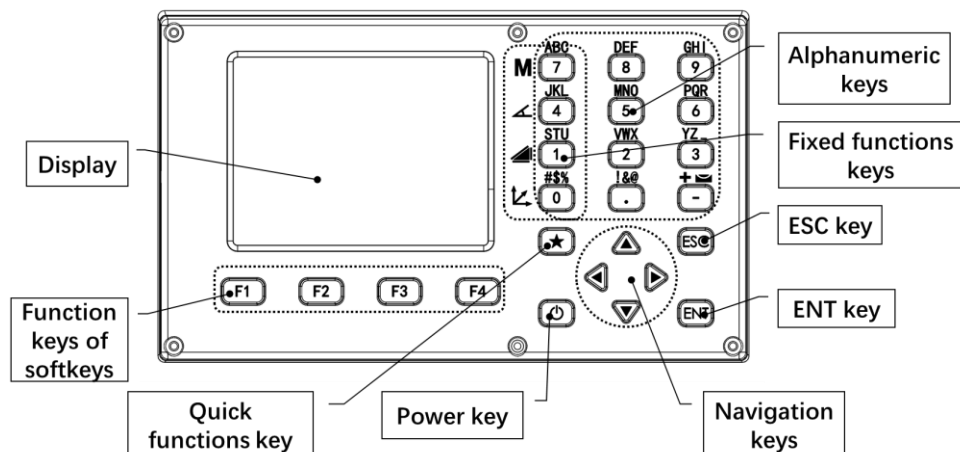





#### Keypad Zones:

- Numeric keys (number/letter/symbol keys)
- Fixed functions keys ("0/1/4/7" multifunctional keys)
- Navigation keys (arrow keys)
- ESC key (escape key)
- ENT key (enter key)
- Power key
- Quick functions key ("★" key)

- Function keys ("F1-4")

**Common Functions of the Keys:**

Key	Function
[0][1]...[9][.][-]	Numeric keys. For entering numbers, letters and common symbol. The keys are also used to select the same number of options in the interface menu.
[.]	Enter "." . Switch on/off the laser pointer in measurement mode.
[-]	Enter "-" . Directly open <b>{level &amp; Plummet}</b> in measurement mode.
[M]	Menu key. Multifunctional key of [7]. Enter <b>{Main Menu}</b> in measurement interface.
[ 	Angle mode key. Multifunctional key of [4]. Switch to the angle mode in measurement interface.
[ 	Distance mode key. Multifunctional key of [1]. Switch to the distance mode in measurement interface.
[ 	Coordinates mode key. Multifunctional key of [0]. Switch to the coordinates mode in measurement interface.
[▲] [▼] [◀] [▶]	Navigation keys, i.e., four arrow keys. [▲] [▼] are primarily used to move up and down in the menu to select activated options or fields. [◀] [▶] are primarily used to move the cursor or toggle specific options for an activated item. [◀] [▶] can also be set as shortcut keys. Refer to <a href="#">Shortcut Keys</a> .
[★]	Quick functions key. Call some common functions directly from the measurement related interface.
[  ]	Power key. Press and hold for power on/off operation.
[ESC]	Escape key. Quit current dialog or the edit mode. Leave the previous value unchanged and return to the previous or higher interface.
[ENT]	Enter key. Confirm an input and continue to the next Field. Confirm an option.
[F1-F4]	Function keys. Press to Call up the assigned functions of corresponding softkey. The currently available softkeys are shown in the bottom softkey bar of the workspace on display, up to four of them, can be activated by corresponding function keys.

## 4. Preparation & Setting up

### 4.1. Battery and Charger

#### Installing / Replacing Battery

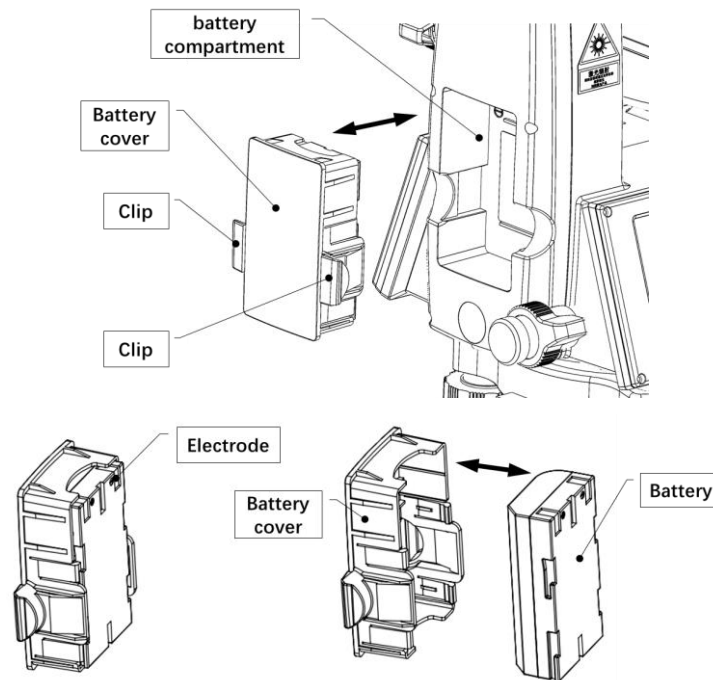

1. With the power off, pinch the clips on either side of the battery cover inward with your thumb and forefinger to unlock it, then gently pull the battery cover outward.
2. Remove the battery from the battery cover.
3. Make sure the battery electrodes are facing outwards and the electrodes are on top and place the new battery into the battery cover. You will hear a clicking sound when the battery is fully inserted., .
4. Make sure that the battery is facing inward, and the electrodes are on top, gently push the battery cover inside the battery compartment of the side cover, and hear a click sound to indicate that the placement is in place, at this time the battery cover should be flush with the side cover.

**NOTE:** There is a product labels in the battery compartment. The label contains important information such as the model number and the serial number of the instrument. When contacting a service center or authorized service center when repair or calibration services are required, customer service may require you to provide the instrument's serial number information.

Please use the charger and battery from STONEX. Store, use and charge at the specified temperature conditions, taking care to avoid contact with liquids.



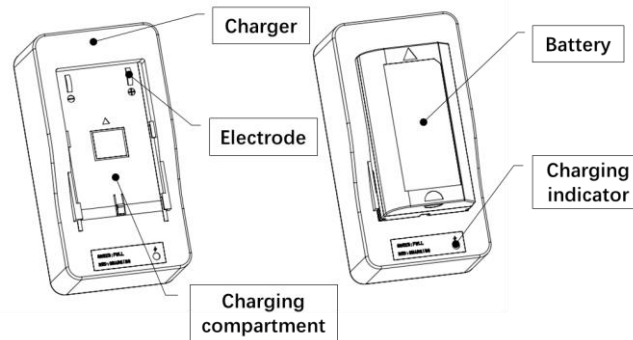

### Charging

1. Remove the charger and cable from the transport case, insert the C8 plug into the charger's corresponding socket for proper connection.
2. Insert the plug of other end properly into a qualified socket with 220V AC, at this time the charging indicator will show green, waiting for charging.
3. With the battery electrodes facing down, push the arrow forward to align with the charger compartment until the battery is stable and settled.
4. If the battery is not fully charged, the charger will begin charging the battery and the charger indicator will now appear red and will turn green again when the battery charge is complete.
5. When charging is complete, pull the battery back to remove it, and then you can install it or use it as a backup battery.

Batteries must be charged before first use. For new batteries or batteries that have been stored for a long time (e.g. more than 3 months), a complete charge/discharge operation can effectively improve battery performance.



It is normal for the temperature of the battery and charger to rise during the charging process. If the temperature is too high, the charger will automatically suspend charging the battery.

Battery operating temperature range: -10°C to +50°C. Low temperature will shorten the operating time of the battery, and too high temperature will shorten the life of the battery.

Remove the battery and unplug the charger after each battery charge. Keep the battery and charger in a safe place.

If you find that the battery level display is significantly inaccurate, it is recommended that you perform a complete charge/discharge operation.

### 4.2. Power on / off

Press and hold  for more than 1 second in the power off state, the instrument will start and automatically enter the measurement interface. Press and hold  for more than 2 seconds in the power-on state, the instrument will prompt to turn off the power and save the current settings, press **[ENT]** to confirm and turn off the power.

Ensure that the battery is charged and properly installed as required.

### 4.3. Setting / Leveling up and Centring

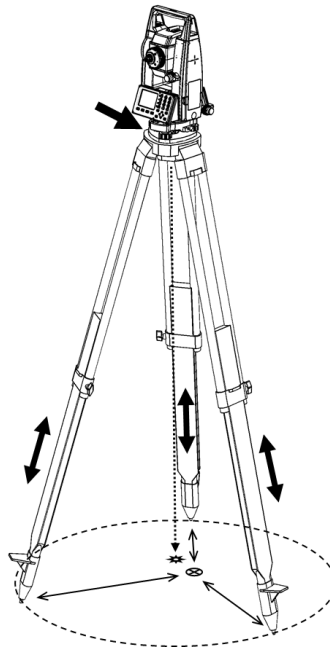

#### Setting up the Tripod and Instrument

1. Adjust the tripod's three legs to nearly equal lengths that meet the height requirements for comfortable measurement.
2. Position the tripod over the station point. The three toes are firmly supported on the ground as equidistantly as possible, the center of the circle formed by the toes is close to the station point, and the tripod plate is nearly horizontal.
3. Take out the instrument and make sure that the instrument and its tribrach are firmly connected. Place the instrument onto the top plate of the tripod, fix the instrument with one hand, align the central knob of the tripod with the center hole of the tribrach with the other hand and tighten it.
4. Gently push the tribrach to make sure it is securely attached to the tripod plate.

#### Leveling up and Centring

1. Press and hold  to power on the instrument. If tilt compensator is on, the laser plummet will automatically light up and project a red spot on the ground and **{Level & Plummet}** will automatically appear.

If the interface of **{Level & Plummet}** does not appear automatically, press **[★]** in the general measurement interface to enter **{Quick Fn}** menu, then press **[4]** **<Level & Plummet>** enter **{Level & Plummet}**.

Press **[-]** in the measurement interface also provides quick access to **{Level & Plummet}**.

The electronic circular level diagram on the left indicates the current leveling state, while the dot at the bullseye indicates leveling.

Quick Fn	
1.	Backlight Set
2.	EDM Set
3.	Pointer Laser (OFF)
4.	Level & Plummet
5.	Beep Sound (ON)
6.	Reticle Illumin (OFF)
7.	Trigger Key (ON)

⟨**2-Axes**⟩ : Indicates the current setting status of tilt compensation, **2-Axes/ 1-Axis/ off**.

⟨**X**⟩ : Indicates the tilt angle of the SA in the X direction, backward positive forward negative.

⟨**Y**⟩ : Indicates the tilt angle of the SA in the Y direction, right positive left negative.

⟨⟩ : Indicates the brightness level of the plummet laser. Press [◀] / [▶]

can adjust the levels with **0-4. 0** means off.

**[F1] [OFF]** : Switch off tilt compensator and exit.

**[F2] [ 1Axis ]** : Switch on single axis tilt compensation, automatically compensate the VA error caused by the SA inclination in X direction.

**[F3] [ 2Axes ]** : Switch on dual-axis tilt compensation, automatically compensate the VA/HA error caused by the SA inclination in both directions.

**[F4] [Back]** : Close {**level & Plummet**}.

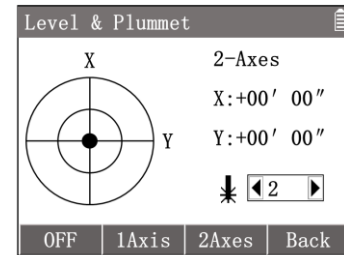

2. Adjust the tripod legs and the tribrach footscrews to centre the plummet laser spot over the station point.
3. Adjust the tripod legs to level the circular level of tribrach.
4. Turn the tribrach footscrews to precisely level the instrument by using the electronic level or tubular level.
5. Slightly loosen the central knob, observe the relative position of the laser spot and the station point, slowly push the tribrach to slide on the tripod plate until the laser spot is precisely aligned with the station point, and then tighten the central knob.
6. Repeat steps 4 and 5 until the required accuracy of leveling and centering is achieved.

If you can't level the instrument by the tubular level, please calibrate the tubular level.

Avoid looking directly at the laser or its strong reflective light.

Under different lighting and ground conditions, the plummet laser spot on the ground may be too bright or too dark to affect centring judgments. In this case, you need to adjust the brightness of the laser. In {**Level & Plummet**}, use the [◀] / [▶] to directly adjust the laser brightness level, each key press will be adjusted by 25%.

#### 4.4. Tilt Compensation

When using the instrument for measurement, since the instrument is not precisely leveled up, that is, the SA of the instrument still has an inclination relative to the direction of the zenith (plumbing), this will bring errors to the measurement of VA/HA. The SA tilt is not the error of the instrument itself, which cannot be eliminated by double-faced observation. The automatic tilt compensation function of the instrument can reduce the influence of SA tilt on the measurement accuracy.

When the function of ⟨**2-Axes**⟩ in {**Level & plummet**} is switched on, the instrument can automatically correct the error caused by the SA tilt, i.e., it can compensate the VA/HA automatically.

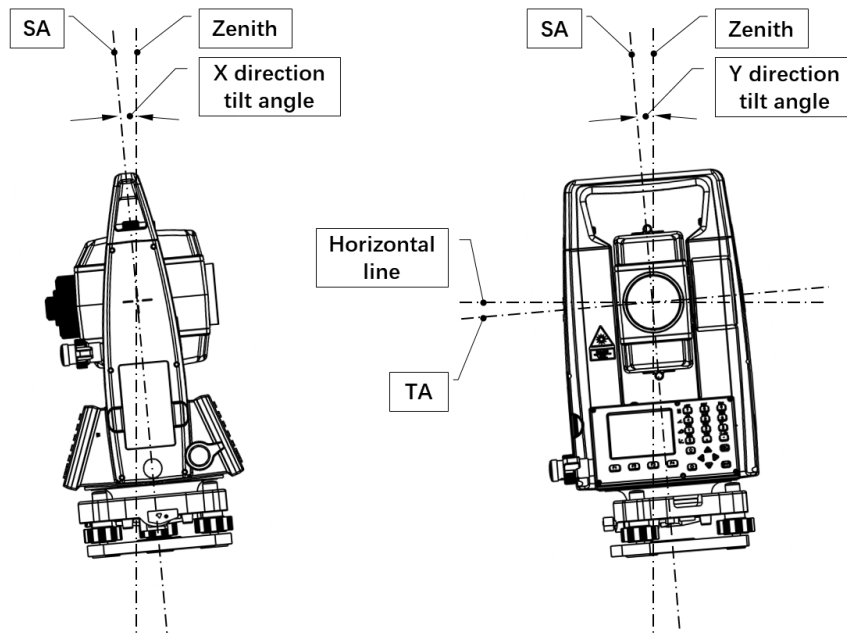

The SA tilt of the instrument is the angle between the direction of the SA and the direction of the zenith (plumbing), which can be decomposed into two rectangular components, i.e., the X and Y direction tilt angle.  
 X direction tilt angle: The X-plane is the plane formed by rotation of the SA along the TA of the instrument. The SA tilt angle projected in the X-plane, i.e., the X direction tilt angle.

Y direction tilt angle: The Y-plane is the plane formed by SA and TA of the instrument. The SA tilt angle projected in the Y-plane, i.e., the Y direction tilt angle.

When the instrument is in operation, if the 2-Axis tilt compensation is on, the instrument will compensate and correct the VA and HA readings in real time. If the SA tilt angle out of the compensation range and continues for more than 5 seconds, the instrument will pop up **{Level & Plummet}** to guide the operator to check the tilt status of the instrument and to level it.

The tilt compensation function can be set in either **{Level & Plummet}** or **{Setting} - {Angle Setting}**.

To avoid accidental tilting of the instrument which may affect the measurement accuracy, it is recommended that the user always switches on the dual-axis compensation function during normal operation.

If the instrument is set up on an unstable base (e.g. on a shaking platform, ship, etc.), tilt compensation should be switched off. This avoids unexpected error messages and interrupting the measuring process.

#### 4.5. Touch Trigger Key

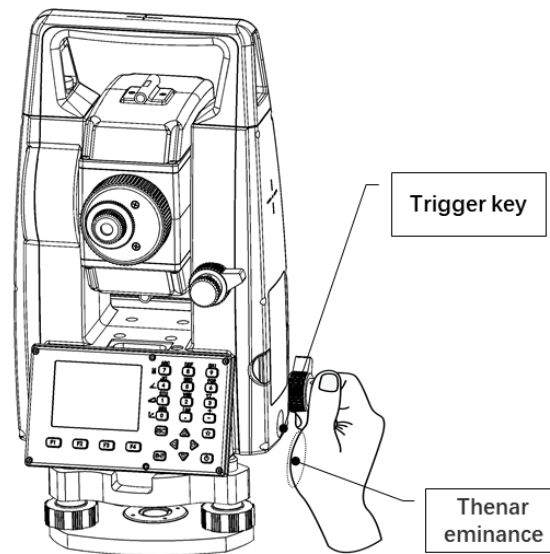

The trigger key is a special area on the side cover of the instrument near the horizontal drive. The trigger key is touch driven. It is designed to trigger the measurement function by lightly touching the area with the thenar eminence or any finger.

In the actual operation, the right hand is often held at the horizontal drive when aiming, so that when a measurement is required it can be triggered by simply touching the trigger area. Due to the fixed position and near to the the hand during operation, there is no need to move the hand away from the horizontal drive or to take the eye off the eyepiece to determine the position of a function key on keypad. Neither the eye nor the hand needs to leave the working position, which is a significant efficiency gain for continuous and extensive measurement work. The trigger key's function can be set as the function of softkey **[Dist]** or **[All]** or inactive.

Refer to [Other Settings](#).

#### 4.6. Display & Main Menu

When the instrument is switched on, the display will show different interfaces in different working procedures. Generally the interface is divided into three areas from top to bottom, including status bar, workspace and softkey bar.

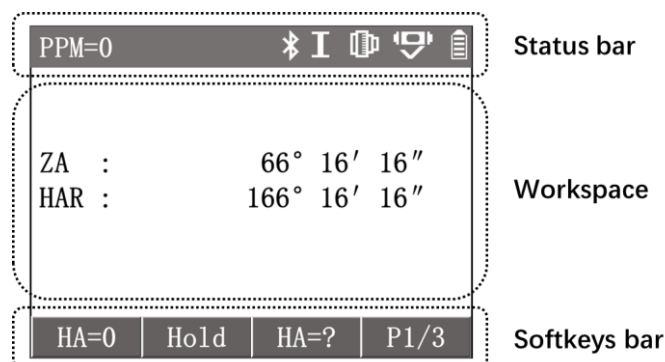

**Status bar:** Displays the current measurement status information icons under the measurement interface. Other interfaces indicate the name of the current interface or procedure, as well as necessary information icons.

**Workspace:** Displays current measurement data, options, input areas, menus, lists, dialogs, and other work content. Guides the operator to read, record, select, confirm, input, and so on.

**Softkey bar:** Displays the softkeys for the current interface, which can be activated by the corresponding function keys [F1-F4]. If there are more than four options, the rightmost softkey will usually be the page down function. The actual functionality represented by each of the soft keys will vary from different interfaces and procedures.

**NOTE:** The workspace content, status icons and softkeys may vary slightly depending on the firmware version of the instrument.

The measurement interface is the basic interface of the instrument, and the display will enter the measurement interface after power on. Pressing [ESC] several times in most of the working interfaces will also eventually return to the measurement interface.

For more instrument operation, you need to go to **{Main Menu}** to make a selection.

In the measurement interface, press [M] to enter **{Main Menu}**. There are six icons to choose from. Use the navigation keys to select an icon and press [ENT] to enter or press the numeric key corresponding to the icon's serial number to enter directly.

- ⟨1.File⟩ : Enter **{File Manager}**.
- ⟨2.Survey⟩ : Enter **{Surveying&Stake Out}**.
- ⟨3.Apps⟩ : Enter **{Applications}**.
- ⟨4.Set⟩ : Enter **{Setting}**.
- ⟨5.Calib⟩ : Enter **{Calibration}**.
- ⟨6.System⟩ : Enter **{System Informaton}**.

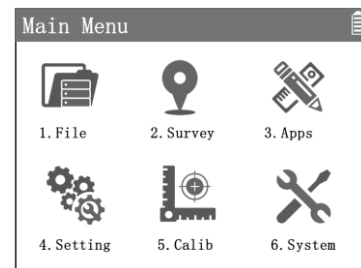

## 4.7. Quick Functions

Some common functions can be called directly from the measurement related interface by pressing [★] .

Press [★] in the measurement related interfaces to enter **{Quick Fn}**.

Use [▲] [▼] to highlight an option and press [ENT] to execute or press the numeric key corresponding to the option's serial number to execute directly.

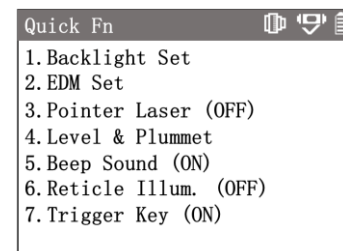

Item	Description
⟨1. Backlight Set⟩	Enter <b>{Backlight}</b> to set the lightness of the display. Press [◀] / [▶] can adjust the lightness from 0% to 100% with a gradient of 10%.
⟨2. EDM Set⟩	Enter <b>{EDM Setting}</b> for EDM related settings.
⟨3. Pointer Laser⟩	Switch on/off the red pointer laser to indicate the collimation point at short range.

<b>&lt;4. Level &amp; Plummet&gt;</b>	Enter <b>{level &amp; Plummet}</b> to switch on and set the plummet laser, set tilt compensation mode, and perform leveling.
<b>&lt;5. Beep Sound&gt;</b>	Switch on/off the buzzer. When switch on, the key tone and beep will be activated.
<b>&lt;6. Reticle Illum.&gt;</b>	Switch on/off the illumination of the reticle.
<b>&lt;7. Trigger Key&gt;</b>	Switch on/off the function of the trigger key.

## 4.8. Edit

### Input

In some procedures, the operator is required to input numbers or characters.

**Input numbers:** In the input field, press **[F4] [123]** to switch to numeric input mode. Only numbers and the "-" and "." symbols can be entered. A short press on a numeric key will input the corresponding number or character in the active input box on the display.

**Input characters:** In the input field, press **[F4] [ABC]** to switch to character input mode. Capital letters, numbers and common symbols can be entered. Click a numeric key to enter the letter, number or symbol corresponding to the key. A quick repetitive press will switch and cycle between the numbers and the letters and symbols printed above the keys. For example, the key **[1]**, press once to input "**S**", press again to input "**T**", press again to input "**U**", press again to input "**1**", press again to input "**S**", ...

### Edit

Existing strings in the input field can be edited.

<b>Key</b>	<b>Description</b>
<b>[◀]</b>	Move the cursor to the left.
<b>[▶]</b>	Move the cursor to the right.
<b>[F1] [Select]</b>	Toggle the input mode between insert and modify. The cursor state is either a vertical line between characters or a block covering a character, respectively.
<b>[F2] [Delete]</b>	Delete a character to the left of the cursor.
<b>[F3] [Clear]</b>	Clear all the characters of the current input field.
<b>[F4] [123/ABC]</b>	Switch the numeric input or character input mode.

### Search

In the interface that supports search, the softkey **[Search]** will be available. Search is used in file management or applications to find specific measured or fixed points in memory. The search function requires entering the exact point name.

The search can be limited to a specific job or to all records. A fixed point that satisfies the search criteria is always

displayed before the measured point. If there are more than one point that meet the search criteria, the results are sorted by the date they were recorded, with the newest point at the top of the search results.

#### 4.9. Focusing and Collimating

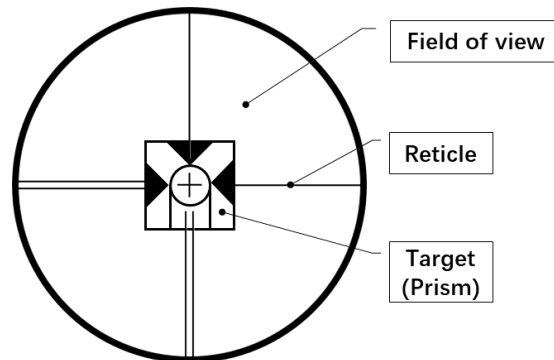

General focus and collimate process:

1. Dioptr adjustment  
Looking through telescope at a bright monochromatic background. Turn the eyepiece's diopter ring clockwise to the end, observe the reticle, slowly turn the ring counterclockwise until the reticle image is sharp and clear.
2. Rough targeting  
Release the horizontal and vertical lock triggers counterclockwise, rotate the telescope to aim for the target with the optical sight, observe from the eyepiece to confirm that the target is in the field of view, then lock both triggers clockwise.
3. Focusing  
Observe the target from the eyepiece, slowly turn the focusing ring until the target image is sharp and clear.
4. Precisely collimating  
Observe the target from the eyepiece, adjust the horizontal and vertical drive to aim the reticle precisely at the center of the target. The final direction of rotation of the drives are always recommended to be clockwise.
5. Repeat 3 and 4 until the target and reticle image are all clear, and both centers are precisely aligned.
6. Start measuring.



## 5. Measurement

### 5.1. Measurement Interface

The measurement interface is the basic interface of the instrument, and the display will enter the measurement interface after power on. Pressing **[ESC]** several times in most of the working interfaces will also eventually return to the measurement interface.

The measurement interface has three modes. Press fixed functions keys (**[4/1/0]** multifunctional keys) can switch the measurement interface to Angle/Distance/Coordinates modes.

The default measurement interface can be set as angle measurement or distance measurement, please refer to [Default Interface](#).

**NOTE:** If tilt compensator is on and the SA tilt angle out of the compensation range and continues for more than 5 seconds, the instrument will pop up **{Level & Plummet}** to guide the operator to check the tilt status of the instrument and to level it.

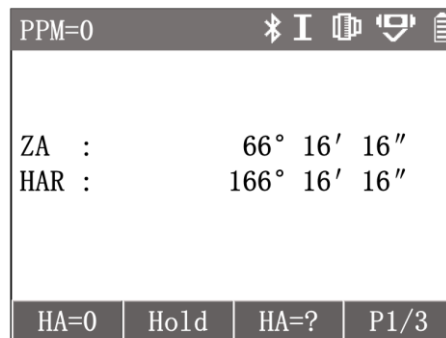

#### Measurement Status Icons

There are some current measurement status icons in the status bar of the measurement interface.

#### Atmospheric Correction Value

**PPM=N** The current PPM value is N, i.e., the atmospheric correction value is N, which not include projection scale factor and inputted PPM.

#### Bluetooth Status:

Indicates the current status of bluetooth function (no icon is displayed when it is off).

 Indicates that the instrument's bluetooth function is turned on.

#### Telescope Position:

Indicates the current status of telescope position/face (**I** or **II**).

**I** Telescope is on position/face **I**.  
**II** Telescope is on position/face **II**.

#### EDM Type:

Indicates the current target type of EDM.



Current target is reflector prism. The prism offset (constant) can be set by the user.



Current target is reflectorless.



Current target is reflector tape.

### Tilt Compensator Status



Tilt compensator is on (2-Axes or 1-Axis).



Tilt compensator is off.

### Battery Capacity:

Indicates the estimated remaining battery capacity.



Show current battery capacity in four levels.

Due to various environmental conditions and different working modes, the remaining battery capacity is only a reference value and cannot accurately indicate the remaining operating time of the instrument. When the icon shows one cell or less, please replace or charge the battery promptly

### Softkeys of Measurement

In the measurement interfaces, the soft keys correspond to different functions in different measurement modes.

#### Angle Measurement:

Press the  fixed function key in the measurement interface to enter the angle measurement mode.

Page	Key	Softkey	Function
1	[F1]	<b>[HA=0]</b>	Set the horizontal angle to 0°00'00".
	[F2]	<b>[Hold]</b>	Lock current horizontal angle.
	[F3]	<b>[HA=?]</b>	Input custom horizontal angles.
	[F4]	<b>[P1/3]</b>	Turn to the 2 <sup>nd</sup> page of softkeys.
2	[F1]	<b>[Level]</b>	Enter <b>{Level &amp; Plummet}</b> .
	[F2]	<b>[ReMeas]</b>	Enter <b>{Re-measure}</b> to HA's repetitive measurement.
	[F3]	<b>[V%]</b>	Display vertical angle in percentage slope mode.
	[F4]	<b>[P2/3]</b>	Turn to the 3 <sup>rd</sup> page of softkeys.
3	[F1]	<b>[R/L]</b>	Convert HA incrementation between right and left, i.e., clockwise and counterclockwise directions.
	[F3]	<b>[VA/ZA]</b>	Vertical angle display format, switch between horizontal zero and zenith zero.
	[F4]	<b>[P3/3]</b>	Turn to the 1 <sup>st</sup> page of softkeys.

### Distance Measurement:

Press the  fixed function key in the measurement interface to enter the distance measurement mode.

Page	Key	Softkey	Function
1	[F1]	<b>[Dist]</b>	Trigger distance measurement.
	[F2]	<b>[HA=0]</b>	Set the horizontal angle to 0°00'00".
	[F3]	<b>[EDM]</b>	Enter <b>{EDM Setting}</b> .
	[F4]	<b>[P1/2]</b>	Turn to the 2 <sup>nd</sup> page of softkeys.
2	[F1]	<b>[Offset]</b>	Enter <b>{Offset}</b> .
	[F2]	<b>[StOut]</b>	Enter <b>{Stake Out}</b> .
	[F3]	<b>[m/ft]</b>	Convert distance units between meters and inches.
	[F4]	<b>[P2/2]</b>	Turn to the 1 <sup>st</sup> page of softkeys.

### Coordinates Measurement:

Press the  fixed function key in the measurement interface to enter the coordinates measurement mode.

Page	Key	Softkey	Function
1	[F1]	<b>[Dist]</b>	Trigger distance measurement.
	[F2]	<b>[HA=0]</b>	Set the horizontal angle to 0°00'00".
	[F3]	<b>[EDM]</b>	Enter <b>{EDM Setting}</b> .
	[F4]	<b>[P1/3]</b>	Turn to the 2 <sup>nd</sup> page of softkeys.
2	[F1]	<b>[hr]</b>	Input the prism height.
	[F2]	<b>[hi]</b>	Input the instrument height.
	[F3]	<b>[STN]</b>	Enter <b>{Set Station}</b>
	[F4]	<b>[P2/3]</b>	Turn to the 3 <sup>rd</sup> page of softkeys.
3	[F1]	<b>[Offset]</b>	Enter <b>{Offset}</b> .
	[F2]	<b>[BS]</b>	Enter <b>{Back Sight}</b> .
	[F3]	<b>[m/ft]</b>	Convert distance units between meters and inches.
	[F4]	<b>[P3/3]</b>	Turn to the 1 <sup>st</sup> page of softkeys.

## 5.2. Angle Measurement

### Measure the HA and VA

Press [] in the measurement interface to enter the angle measurement mode.

1. Aim at target A. The workspace displays current **⟨HAR⟩** and **⟨ZA⟩** .
2. Press **[F1] [HA=0]** enter **{HA=0}**, Press **[F4] [YES]** , set **⟨HAR⟩** to **⟨0°00'00″⟩** .
3. Aim at target B. The workspace displays the **⟨HAR⟩** between A and B. Also displays the **⟨ZA⟩** of B.

**[F3] [NO]** : return to the previous interface.

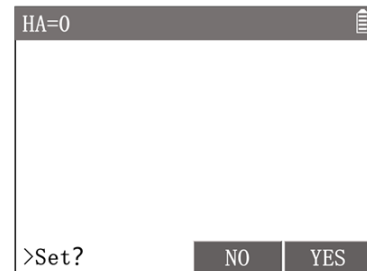
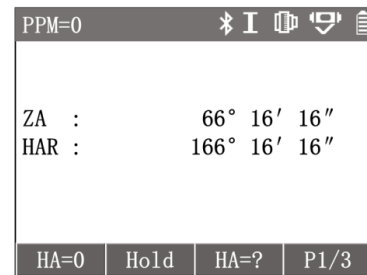

### Toggle HAR/HAL

Convert HA incrementation between right and left, i.e. HAR and HAL:

Press **[F4]** twice to 3<sup>rd</sup> page of softkeys, press **[F1] [R/L]** to toggle between **⟨HAR⟩** and **⟨HAL⟩** .

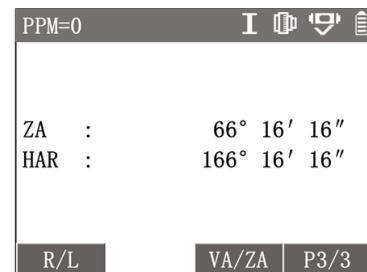

### Hold the HA:

Set the HA by locking current HA value.

1. Rotate the instrument, use the horizontal drive to adjust to the required HA value.
2. Press **[F2] [Hold]** enter **{Hold}**, the HA will be locked and not changed with the rotation of the instrument.
3. Aim at the target, press **[F4] [YES]** back to angle measurement interface , the HA will remain the locked value.

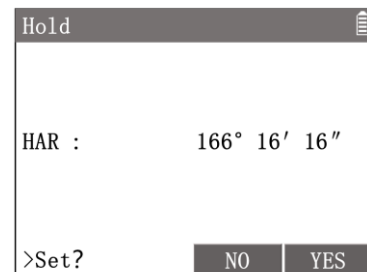

### Input Custom HA:

Horizontal angle setting via keyboard input.

1. Aim at the target.
2. Press **[F3] [HA=?]** enter **{HA=?}**.
3. Input the HA value needed, e.g. **90°00'00″**, Press **[F4] [YES]** to confirm setting.

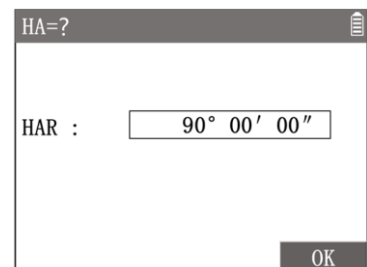

When **{Unit Setting} ⟨AngleUnit⟩** is set to **⟨°″⟩** , the integer part of the inputted angle value is degrees, the first two decimal places are minutes, three and four decimal places are seconds, and five decimal places and subsequent numbers will be rounded off.

### Switch ZA/VA in Percentage Slope Mode

1. Press **[F4]** to 2<sup>nd</sup> page of softkeys.
2. Press **[F3] [V%]** to switch the modes between vertical angle and slope.

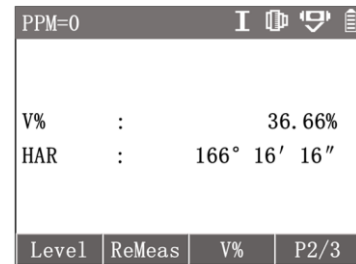

Each time the **[F3]** key is pressed, the display mode switches alternately, and **[V%]** value is no longer displayed when the slope is greater than 300%.

#### HA Re-measurement

1. Press **[F4]** to 2<sup>nd</sup> page of softkeys, press **[F2] [ReMeas]** .
2. Pre **[ENT] [YES]** enter **{Re-measure}**.
3. Aim at target A, Press **[F2] [HA=0]** , Press **[ENT] [YES]** .
4. Aim at target B, press **[F4] [Hold]** , complete the first observation.
5. Aim at target A again, press **[F3] [Leave]** .
6. Aim at target B again, press **[F4] [Hold]** , complete the second observation.
7. Repeat steps ⑤ and ⑥ for the required number of measurements.
8. Press **[ESC]** to exit **{Re-measure}** to the angle measurement.

**<Ht>** : The cumulative value of HA.

**<Hm>** : The Average of multiple measurements.

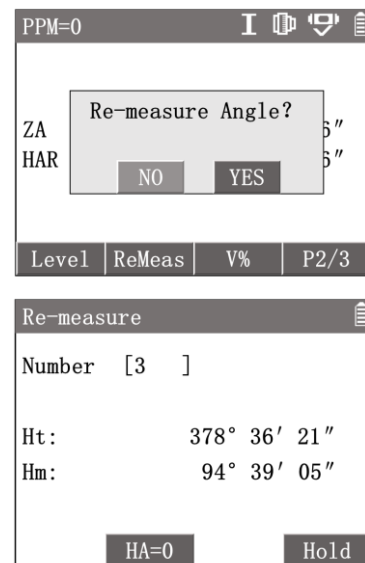

**Ht** can be angle values over 360 degrees. The maximum value of **<Ht>** is 3600°00'00".

If the absolute value of the difference between this round angle value and the current **<Hm>** value is greater than 10", "**Aiming error. Ignore. Release again!**" will pop up. Then you need to press **[F3] [Leave]** and aim the target more precisely again.

#### Toggle VA/ZA

1. Press **[F4]** twice to 3<sup>rd</sup> page of softkeys.
2. Press **[F3] [VA/ZA]** to switch the **<ZA>** to **<VA>** . The horizontal direction is zero.
3. Press **[F3] [VA/ZA]** again, switch the **<VA>** back to **<ZA>** . The zenith direction is zero.

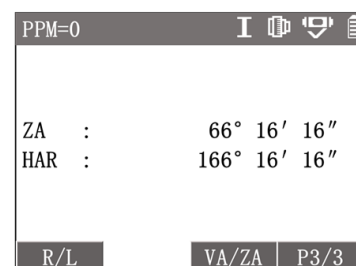

**<ZA>** is the vertical angle that defines the zenith as zero. **<VA>** is the vertical angle that defines the horizontal as zero. Each time the **[F3]** key is pressed, the mode switches alternately. This softkey is not available when the vertical angle is switched to slope.

### 5.3. Distance Measurement

Press  in the measurement interface to enter the distance measurement mode.



Workspace contain **<ZA>** , **<HAR>** , **<SD>** , **<HD>** , **<VD>** .

Aim at the target, press **[F1] [Dist]** to trigger the distance measurement and get result.

**[F3] [EDM]** : enter **{EDM setting}**.

2<sup>nd</sup> page of softkeys **[F3] [m/ft]** : Convert distance units between meters and inches.

For details on EDM settings, refer to [EDM Settings](#).

PPM=0		I			
ZA :	0° 00' 00"				
HAR :	0° 00' 00"				
SD :	----- . --- m				
HD :	----- . --- m				
VD :	----- . --- m				
Dist	HA=0	EDM	P1/2		

EDM is the abbreviation for Electronic Distance Meter. The total station has a built-in laser EDM, which uses the red visible laser emitted by the telescope coaxially to reach the target and then return to measure the distance.

There can be three types of EDM targets:

- Prism: The targets are various specialized reflector prisms which may have different prism constant.
- Tape: The targets are specialized reflector tapes which can adhere to the target surface.
- NonPrism: Reflectorless. The targets are on the surface of objects.

Caution:

- When performing distance measurements, if there are any obstacles (such as passing pedestrians, cars, or dust, smoke, leaves etc. that affect the passage of laser) on the optical path where the distance is measured, the EDM function may not work, or the measured result may be the distance to the nearest obstacle.
- Avoid objects such as glass, water, traffic signs, etc. near the measurement target or light path, that may alter the light path.
- Do not use 2 instruments to measure a single target at the same time.
- Avoid measuring any strongly reflective targets that are not reflector prisms, such as traffic lights, traffic signs, etc., in prism mode.
- When using a reflector tape for distance measurement, the laser beam is required to be as perpendicular to the tape as possible to ensure measurement accuracy.
- Precise measurement operations must be carried out in the prism mode and the correct prism constant must be set according to the prism type.

## 5.4. Coordinates Measurement

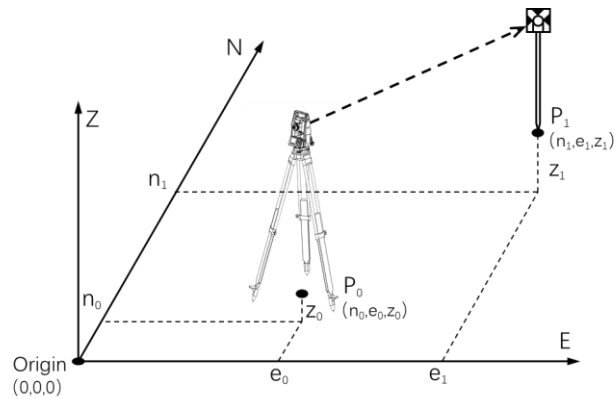

Press [] in the measurement interface to enter the coordinate measurement mode.

Aim at the target, press **[F1] [Dist]** to trigger the distance measurement and get the coordinates.



If no station is set, the default coordinate of current station  $P_0$  is the origin (0,0,0).

## 6. Survey

Applications are programs that perform various specific surveying, stake out, and calculation functions. The applications are divided into two categories, which are in **<2.Survey>** and **<3.Apps>** in **{Main Menu}**. The most commonly used **{Surveying}** and **{Stake Out}** are in the **<2.Survey>** **{Surveying & Stake Out}**, while the rest are in **<3.Apps>** **{Applications}**.

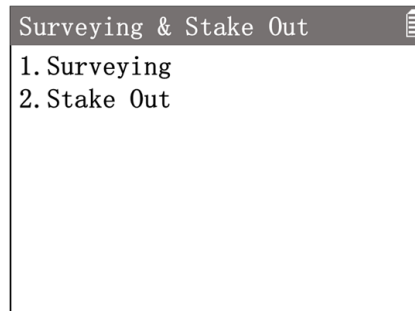

Before performing an application task, some necessary preparations are generally required (e.g., set station, job, orientation). After accessing an application (**Suveying, Stake Out, Offset, Reference Line**, etc.), the corresponding pre-setting programs are accessed, which allows the operator to select and follow the step-by-step instructions to set them up.

For example, in the measurement interface, press **[M]** to enter **{Main Menu}**, use the navigation keys to select **<2.Survey>** and press **[ENT]**, or simply press the numeric key **[2]** to enter **{Surveying & Stake Out}**. Then select **<1.Surveying>** and press **[ENT]** to enter **{Surveying}**.

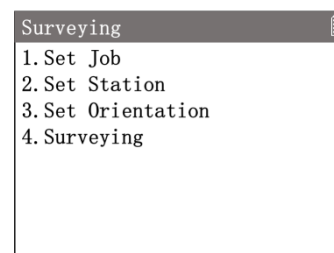
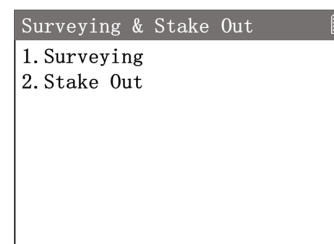

### Set Job:

All data is saved in jobs, which contain different types of data (e.g. measurements, codes, fixed points, stations, etc.). The job can be created, read, edited, or deleted.

In **{Surveying}** Press **[1]** **<1.Set Job>** to enter **{Set Job}**. The workspace displays current job's information.

**[F1] [List]** : Enter **{Job Manager}**, list all the existing jobs, which can be selected, deleted or checked.

**[F2] [New]** : Create a new job by inputting the names of **<Job>** and **<User>** (User name can be left out).

**[F4] [OK]** : Set the job as current job.



If the application is started without setting a job, the default job will be the previous job. If there is no any job been



created, the default job will be the job named 'Default'.

**Set Station:**

The station coordinates can be read from the instrument memory or set by manual input.

1. In **{Surveying}** press **[2]** **<2.Set Station>** to enter **{Set Station}**. The workspace displays current station's information.
2. Input **<hi>** (instrument height).

**[F1] [List]** : Enter **{Known Point List}** to select a known point as the station.

**[F2] [Input]** : Enter **{New Point}** to create a station point by manual input.

**[F3] [Back]** : Back to previous interface.

**[F4] [OK]** : Set the station.

Set Station					
N :	0.000m				
E :	0.000m				
Z :	0.000m				
StationID	Default				
hi :	<input type="text" value="1.400"/> m				
<table border="0"> <tr> <td>List</td> <td>Input</td> <td>Back</td> <td>OK</td> </tr> </table>		List	Input	Back	OK
List	Input	Back	OK		

Known Point List					
Fixed Point, 1					
Fixed Point, 5					
Observation, 1					
Observation, 2					
<table border="0"> <tr> <td>View</td> <td>Search</td> <td>OK</td> <td>P1/2</td> </tr> </table>		View	Search	OK	P1/2
View	Search	OK	P1/2		

New Point			
N :	<input type="text"/> m		
E :	<input type="text"/> m		
Z :	<input type="text"/> m		
PointID:	<input type="text" value="8"/>		
Code:	<input type="text"/>		
<table border="0"> <tr> <td>Back</td> <td>Rec</td> </tr> </table>		Back	Rec
Back	Rec		

The applications' measurements, coordinates, and calculations are related to the current station coordinates, which should contain at least the plane coordinate (N, E) and, if required for the job, the height (Z).

If the application is started without setting station, the instrument defaults to the last setup station as the current station.

**Set Orientation:**

With the orientation, the horizontal direction angle can be set by manual input or set by known point coordinates.

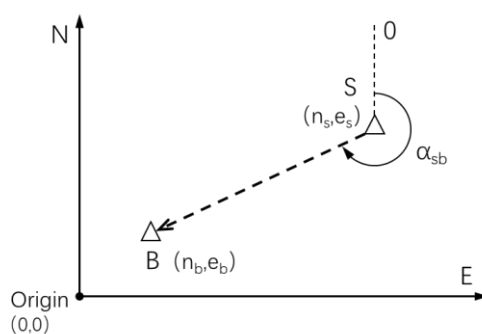

- S: Station
- ( $n_s, e_s$ ): Station coordinates
- B: Backsight point
- ( $n_b, e_b$ ): Known coordinates
- $\alpha_{sb}$ : HA of S-B direction

**Angle Orientation:**

Set orientation by directly inputting an orientation HA of the direction from current station to the backsight point.

1. In **{Surveying}** press **[3]** **<3.Set Orientation>** to enter **{Back Sight}**.
2. Press **[1]** **<Angle Orientation>** to enter **{BS Angle}**.
3. Input the **<PointID>** and **<HA>** value then Press **[F4]** **[OK]** .
4. Aim at the backsight point and press **[ENT]** **<YES>** to set the orientation.

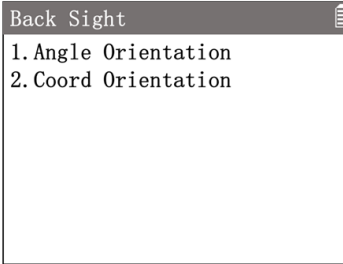

```

Back Sight
1.Angle Orientation
2.Coord Orientation
  
```

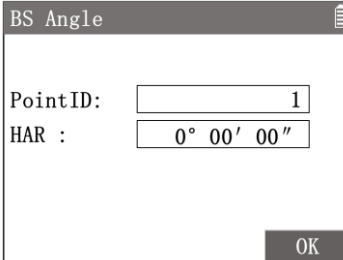

```

BS Angle
PointID: 1
HAR : 0° 00' 00"
OK
  
```

### Coordinates Orientation:

Set orientation by known point's coordinates. The coordinates can be read from the instrument memory or set by manual input.

1. In **{Surveying}** press **[3]** **<3.Set Orientation>** to enter **{Back Sight}**.
2. Press **[2]** **<Coord Orientation>** to enter **{BS Coordinates}**.  
**[F1] [List]** : Enter **{Known Point List}** to select a known point as the backsight point.  
**[F2] [Input]** : Enter **{New Point}** to create a known point by manual input.
3. Input **<hr>** (prism height) then press **[F4] [OK]** .
4. Aim at the backsight point and press **[ENT]** **<YES>** to set the orientation.
5. Enter **{Backsight Check}**. Workspace display the HA and calculated HD.
6. Press **[F1] [Dist]** to trigger the measurement. Check the measured HD deviation, press **[F4] [OK]** to set the orientation.

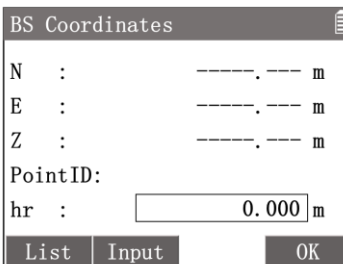

```

BS Coordinates
N : ----- m
E : ----- m
Z : ----- m
PointID:
hr : 0.000 m
List Input OK
  
```

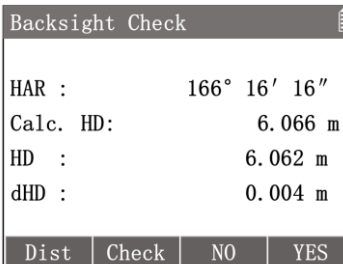

```

Backsight Check
HAR : 166° 16' 16"
Calc. HD: 6.066 m
HD : 6.062 m
dHD : 0.004 m
Dist Check NO YES
  
```

**<HAR>** : HA to the backsight point.

**<Calc. HD>** : Calculated HD to backsight point.

**<HD>** : Measured HD to backsight point.

**<dHD>** :The deviation between **<Calc. HD>** and **<HD>** .

**[F2] [Check]** :View the backsight coordinates.

**[F3] [NO]** : Ignore current setting result and back to **{BS Coordinates}**.

**[F3] [YES]** : Set the orientation.

## 6.1. Surveying

Application to measure a point and record the data.

1. In the measurement interface, press **[M]** to enter **{Main Menu}**.
2. Use the navigation keys to select **⟨2.Survey⟩** and press **[ENT]**, or simply press the numeric key **[2]** to enter **{Surveying & Stake Out}**. Press **[1]** to enter **{Surveying}**.
3. Perform pre-settings.
4. Press **[4]** to enter **{Surveying}**. Input the **⟨PointID⟩** and **⟨hr⟩**.
5. Aim at the target then trigger the measurement.

**[F1] [Dist]** : Trigger the distance measurement and display the result.

**[F2] [Mode]** : Convert the display data between coordinates, angle, and distance.

**[F3] [Rec]** : Record the measurement result. and **⟨PointID⟩** automatically adds 1.

**[F4] [All]** : Trigger the distance measurement and record the result. Then **⟨PointID⟩** automatically adds 1.

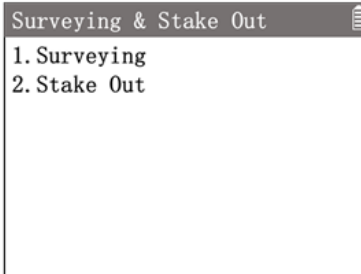

```

Surveying & Stake Out
1. Surveying
2. Stake Out
    
```

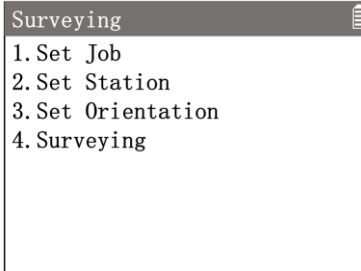

```

Surveying
1. Set Job
2. Set Station
3. Set Orientation
4. Surveying
    
```

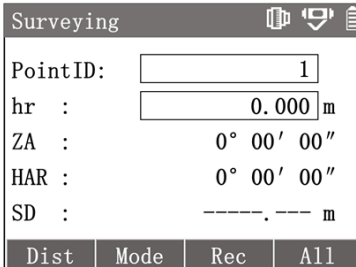

```

Surveying
PointID: 1
hr : 0.000 m
ZA : 0° 00' 00"
HAR : 0° 00' 00"
SD : ----.--- m
Dist | Mode | Rec | All
    
```

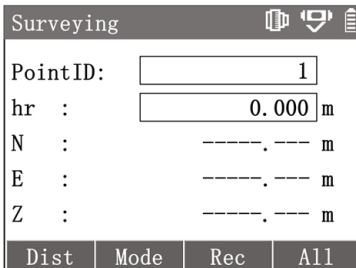

```

Surveying
PointID: 1
hr : 0.000 m
N : ----.--- m
E : ----.--- m
Z : ----.--- m
Dist | Mode | Rec | All
    
```

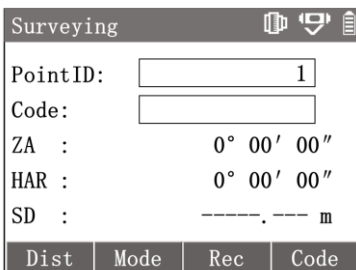

```

Surveying
PointID: 1
Code:
ZA : 0° 00' 00"
HAR : 0° 00' 00"
SD : ----.--- m
Dist | Mode | Rec | Code
    
```

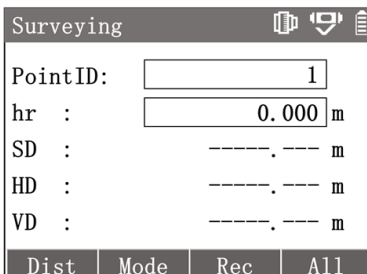

```

Surveying
PointID: 1
hr : 0.000 m
SD : ----.--- m
HD : ----.--- m
VD : ----.--- m
Dist | Mode | Rec | All
    
```

If not perform distance measurement and directly press **[F3] [Rec]** , only the angle data would be recorded (no

distance and coordinates data .

In angle mode interface, **<Code>** can be inputted or select form **{Code List}**. Press **[ESC]** to back to the initial **{Surveying}** interface.

## 6.2. Stake Out

This application calculates the required parameters to position the required stakeout point. The stakeout point data can be read from the instrument memory or set by manual input. The program guides the user step by step from the current point to the correct point by continuously displaying the relative position relationship between the current prism point and the point to be stake out.

There are two methods for the process of stake out: the cartesian method and the polar method.

### Cartesian Stake Out:

Stake out method which is based on a cartesian coordinate system. The calculated offset is divided into three orthogonal distance elements.

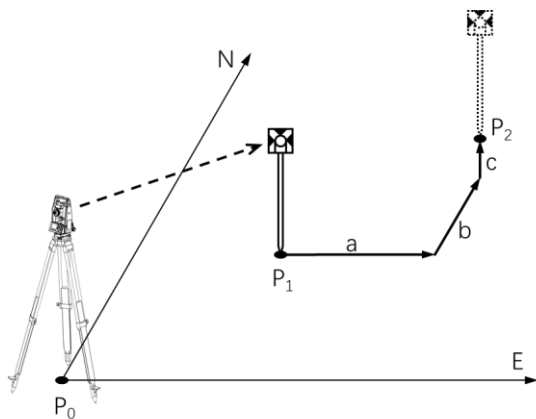

- P<sub>0</sub>: Station
- P<sub>1</sub>: Current point
- P<sub>2</sub>: Stakeout point
- a: dE (East offset)
- b: dN (North offset)
- c: dZ (Height offset)

### Polar Stake Out:

Stake out method which is based on a polar coordinate system. The calculated offset is divided into one angle and two distance elements.

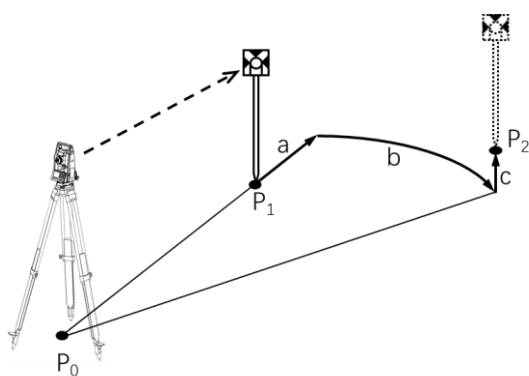

- P<sub>0</sub>: Station
- P<sub>1</sub>: Current point
- P<sub>2</sub>: Stakeout point
- a: dHD  
(Longitudinal offset)
- b: dHA (HA offset)
- c: dh (Height offset)

1. In the measurement interface, press **[M]** to enter **{Main Menu}**.
2. Press **[2]** to enter **{Surveying & Stake Out}**.
3. Press **[2]** to enter **{Stake Out}**.
4. Perform pre-settings.
5. Press **[4]** or **[5]** to choose the stakeout method **<Cartesian Stake Out>** or **<Polar Stake Out>** to enter.

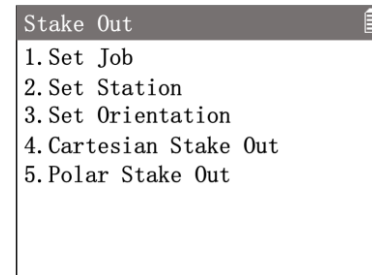
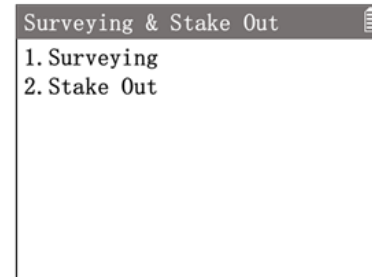

### Cartesian Stake Out:

The stakeout point coordinates can be read from the instrument memory or set by manual input.

Press **[4]** to enter **{Cartesian stake out}**.

Input stakeout point coordinates **<N>** , **<E>** , **<Z>** and **<hr>** .

**[F1] [Rec]** : Record the inputted coordinates point.

**[F2] [List]** : Enter **{Known Point List}** to select a known point as the stakeout point.

**[F4] [OK]** : Confirm point data and enter **{Stake Out}** to perform stake out process.

**{Stake Out}** default workspace is performing cartesian method process.

Aim at the target.

**[F1] [Dist]** : Trigger the distance measurement and display the result.

**<dN>** : North offset.

**<dE>** : East offset.

**<dZ>** : Height offset.

**<HAR>** : Current HA.

**<dHA>** : HA offset.

When the **<dHA>** is 0°00'00", it means that the direction of staking out is correct.

**[F3] [<-->]** : Convet the workspace to stakeout guidance interface.

Press **[F4]** to 2<sup>nd</sup> page of softkeys.

**[F1] [Rec]** : Record the current point measurement result.

**[F2] [HD/Coord]** : Switch the method between cartesian and polar.

**<dHD>** : Longitudinal offset.

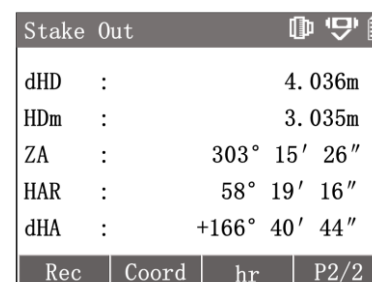
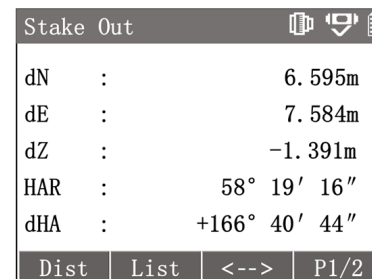
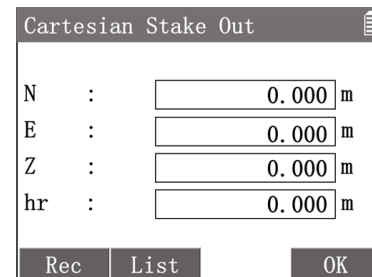

### Polar Stake Out:

Input the longitudinal offset and HA offset to define the stakeout point.

Press **[5]** to enter **{Polar Stake Out}**.

Input **<Dist>** , **<HA>** , **<hr>** to define the stakeout point.

press **[F4] [OK]** to enter **{Stake Out}** guidance interface to perform stake out process.

Polar Stake Out	
Dist :	<input type="text" value="0.000"/> m
HA :	<input type="text" value="0° 00' 00"/> "
hr :	<input type="text" value="0.000"/> m
<b>OK</b>	

### Stake Out Guidance:

Indicates the direction and offset value of target's movement by the polar method.

**First line:** Arrow guide to move left/right and **dHA**.

**Second line:** Direction arrow guide to move and **dHD**.

↓ : Move towards the station.

↑ : Move away from the station.

**Third line:** Direction arrow guide to move and **dZ**.

↓ : Move higher.

↑ : Move lower.

After moving the target according on the guidance, aim at the target again.

Then press **[F1] [Dist]** to trigger the distance measurement again.

Repeat the movement and measurement until the offset values meet the requirements

Stake Out	
→	+166° 40' 44"
↑	4.036m
↓	-1.391m
ZA :	303° 15' 26"
HAR :	58° 19' 16"
Dist	List
<-->	P1/2

## 7. Applications

### 7.1. Offset

In some measurement tasks, it is not easy to set up the reflector prism directly, or it is not possible to aim the target point directly. The offset application can work out the target point by measuring some related offset points which can be measured easily.

1. In the measurement interface, press **[M]** to enter **{Main Menu}**.
2. Use the navigation keys to select **⟨3.Apps⟩** and press **[ENT]**, or simply press the numeric key **[3]** to enter **{Applications}**.
3. Press **[1]** to enter **{Offset}**.
4. Perform pre-settings.

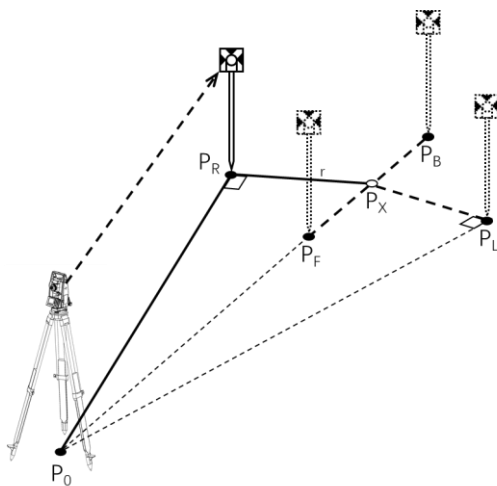
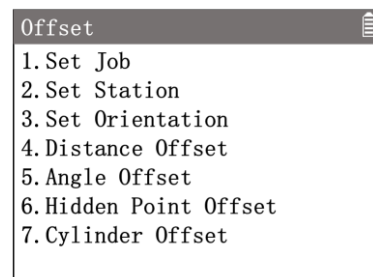
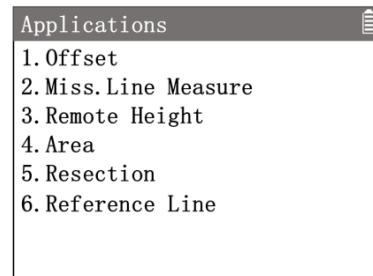

- P<sub>0</sub>: Station
- P<sub>x</sub>: Target point
- P<sub>R</sub>: Measurement point (right)
- P<sub>L</sub>: Measurement point (left)
- P<sub>F</sub>: Measurement point (front)
- P<sub>B</sub>: Measurement point (back)
- r: Offset distance

#### Distance Offset:

Distance offset program requires that the measurement point and the target point are equal in height, and the offset distance is known. It is usually used when the target point is not in view.

1. Press **[4]** **<4.Distance Offset>** to enter **{Distance Offset}**.
2. Use the navigation keys to select **<Offset>** and input the offset distance.
3. Select **<Deviation>** then use **[←] [→]** to change the direction.
  - <Left>** : The measurement point is to the left of the target point.
  - <Right>** : The measurement point is to the right of the target point.
  - <Front>** : The measurement point is in front of the target point.
  - <Back>** : The measurement point is on the back side of the target point.
4. Aim at the measurement point and press **[F1] [Dist]** to trigger the distance measurement. Then press **[F3] [OK]** .
5. Workspace display the calculated result of the target point.
  - [F3] [Shift]** : Convert the display data format between polar and coordinates.
  - [F4] [Rec]** : Record the result data of target point.

Distance Offset	
HD :	----- m
HAR :	0° 00' 00"
PointID:	<input type="text" value="1"/>
Offset:	<input type="text" value="0.000"/> m
Deviation:	<input type="text" value="Left"/>
Dist <span style="float: right;">P1/2</span>	

Distance Offset	
SD :	6.405 m
ZA :	8° 50' 24"
HAR :	228° 49' 33"
Shift Rec	

When the measurement point is to the left or right of the target point, the angle between the measurement point and the target point and the line between the measurement point and the station should be approximately equal to 90 degrees. When the measurement point is located to the front or back side of the target point, the measurement point should be located on the line between the target point and the station.

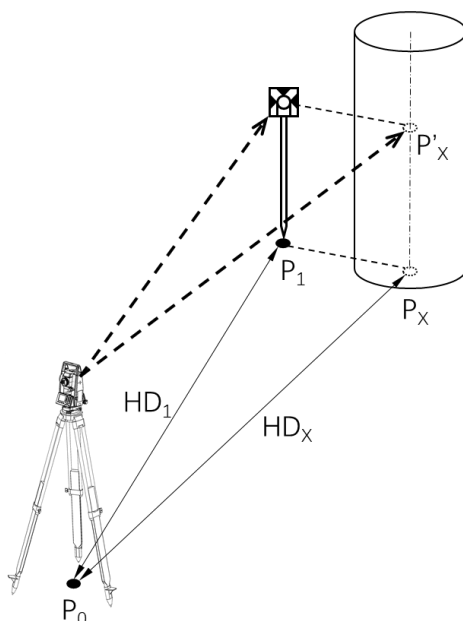

- P<sub>0</sub>: Station
  - P<sub>x</sub>: Target point
  - P<sub>1</sub>: Measurement point
  - P'<sub>x</sub>: Virtual points in the same direction with target point
  - HD<sub>1</sub>: HD of the measurement point
  - HD<sub>x</sub>: HD of the target point
- HD<sub>1</sub>=HD<sub>x</sub>

### Angle Offset:

Angle offset program requires that the target point and the measurement point are equal in height, and have same distance to the station. For the measurement point, the distance and HA needs to be measured. For the target point, only the HA needs to be measured. The application will calculate the coordinates of the target point based on the distance value of the measurement point and the angle value of the target point. This method can



be used to measure the centre of cylindrical targets such as piers, poles or trees.

1. Press **[5]** **<5.Angle Offset>** to enter **{Angle Offset}**.
2. Aim at the measurement point and press **[F1]** **[Dist]** to trigger the distance measurement.

First Target	
PointID:	<input type="text" value="1"/>
hr :	<input type="text" value="0.000"/> m
SD :	----- m
ZA :	84° 09' 23"
HAR :	71° 39' 15"
<b>Dist</b>	

3. Rotate the instrument horizontally to aim at the point which have the same orientation at the target point. Then press **[F3]** **[OK]** .

Second Target	
PointID:	<input type="text" value="1"/>
hr :	<input type="text" value="0.000"/> m
SD :	12.816 m
ZA :	84° 09' 23"
HAR :	72° 45' 43"
<b>OK</b>	

4. Workspace display the calculated result of the target point.  
**[F3]** **[Shift]** : Convert the display data format between polar and coordinates.  
**[F4]** **[Rec]** : Record the result data of target point.

Angle Offset	
SD :	12.816m
ZA :	84° 09' 23"
HAR :	72° 45' 43"
<b>Shift</b> <b>Rec</b>	

The measurement point should be as close as possible to the left or right of the target point. The distance from the measurement point to the station should be equal to the distance from the target point to the station.

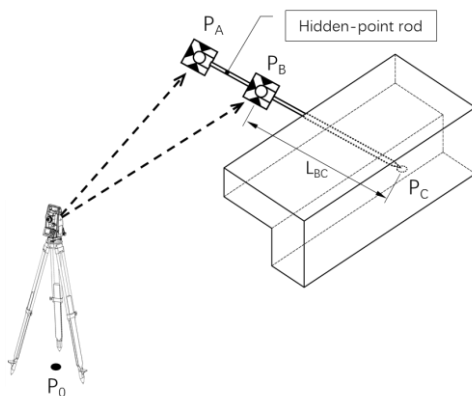

- P<sub>0</sub>: Station
- P<sub>C</sub>: Hidden point
- P<sub>A</sub>: Prism A of rod
- P<sub>B</sub>: Prism B of rod
- L<sub>BC</sub>: Length of B-C (known)

#### Hidden Point Offset:

Hidden point is a target point that is not directly visible. By using a special hidden-point rod whose length was known, hidden point program can be measured indirectly.

Hold the tip of the hidden-point rod against the target point, orient the prism towards the instrument and keep the rod still.

1. Press **[6]** **<6.Hidden Point Offset>** to enter program.
2. Aim at the prism A of rod and press **[F1]** **[Dist]** to trigger the distance measurement. Check the result then press **[F3]** **[Yes]** to record.

First Target	
PointID:	<input type="text" value="1"/>
hr :	<input type="text" value="0.000"/> m
SD :	----- m
ZA :	84° 09' 23"
HAR :	71° 39' 15"
<b>Dist</b>	

First Target	
PointID:	1
N :	16.066 m
E :	-6.006 m
Z :	1.016 m
>Sure? <b>No</b> <b>Yes</b>	

3. Aim at the prism B of rod and press **[F1]** **[Dist]** to trigger the distance measurement. Check the result then press **[F3]** **[Yes]** to record.

4. Input the known length between the prism B and the rod tip C.  
Press **[F3]** **[OK]** to display the calculated result of the target point.

**[F3]** **[Shift]** : Convert the display data format between polar and coordinates.

**[F4]** **[Rec]** : Record the result data of target point.

Input Offset	
B-C:	<input type="text" value="1.500"/> m
<b>OK</b>	

Hidden Point	
SD :	12.816m
ZA :	86° 19' 43"
HAR :	84° 25' 49"
<b>Shift</b> <b>Rec</b>	

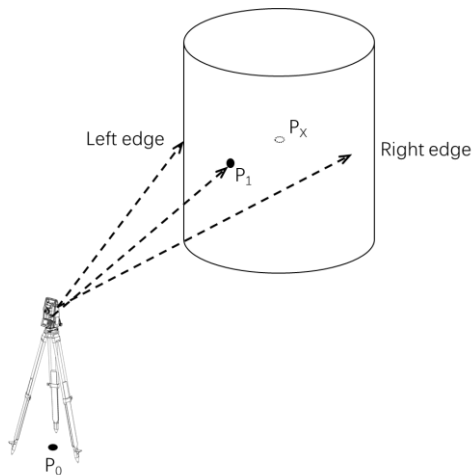

P<sub>0</sub>: Station  
P<sub>x</sub>: Target point  
P<sub>1</sub>: Surface point

### Cylinder Offset:

By measuring a surface point and two edges, cylinder offset program can calculate the center coordinates and the radius of the cylinder.

1. Press **[7]** **<7.Cylinder Offset>** to enter program.
  2. Aim at a surface point of the cylinder and press **[F1] [Dist]** to trigger the distance measurement. Check the result then press **[F3] [OK]** to record.
  3. Rotate the instrument horizontally to aim the reticle at the left edge of the cylinder. Then press **[F3] [OK]** .
  4. Rotate the instrument horizontally to aim the reticle at the right edge of the cylinder. Then press **[F3] [OK]** .
  5. Workspace display the calculated center coordinates and the radius of the cylinder.
- [F2] [END]** : Exit the program.  
**[F3] [Rec]** : Record the center point coordinates.

Surface Point	
PointID:	<input type="text" value="1"/>
hr :	<input type="text" value="0.000"/> m
SD :	----- m
ZA :	84° 09' 23"
HAR :	71° 39' 15"
<b>Dist</b>	

Cylinder Offset	
Aim at Hz left edge	
ZA :	86° 19' 43"
HAR :	69° 16' 56"
<b>OK</b>	

Cylinder Offset	
N :	16.066 m
E :	-6.006 m
Z :	1.016 m
Radius:	6.060 m
<b>END</b>   <b>Rec</b>	

## 7.2. Missing Line Measurement

This application is used to measure and calculate the SD/HD/VD of two target points.

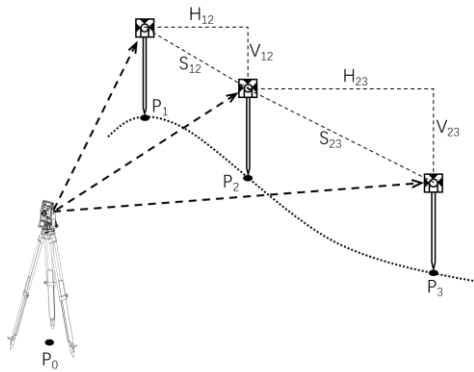

P<sub>0</sub>: Station  
P<sub>1</sub>: First point 1# (Start point)  
P<sub>2</sub>: Second point 2# (New start point)  
P<sub>3</sub>: Third point 3# (New second point)

S<sub>12</sub>: SD between 1# and 2#  
H<sub>12</sub>: HD between 1# and 2#  
V<sub>12</sub>: VD between 1# and 2#  
S<sub>23</sub>: SD between 2# and 3#  
H<sub>23</sub>: HD between 2# and 3#  
V<sub>23</sub>: VD between 2# and 3#

1. In the measurement interface, press **[M]** to enter **{Main Menu}**.
2. Use the navigation keys to select **<3.Apps>** and press **[ENT]**, or simply press the numeric key **[3]** to enter **{Applications}**.
3. Press **[2]** **<2.Miss. Line Measure>** to enter **{MLM First Point}**.
4. Aim at the first point (start point) and press **[F1]** **[Dist]** to trigger the distance measurement.
5. Aim at the second point and press **[F4]** **[MLM]** to trigger the distance measurement and enter **{MLM Second Point}**.

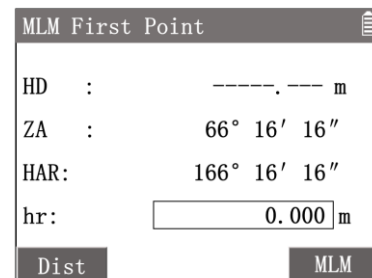
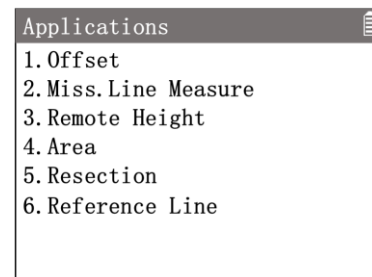

6. Workspace display the calculated distance between the two points and the data of the second point.

**<ML-SD>** : SD between the two points.  
**<ML-HD>** : HD between the two points.  
**<ML-VD>** : VD between the two points.  
**<HD>** : HD between the second point and station.  
**<HAR>** : HAR of the second point.  
**<hr>** : Input the prism height.

- [F1] [Dist]** : Measure a new start point.  
**[F2] [Move]** : Set the second point as new start point.  
**[F3] [SD/Slope]** : Switch the display modes between SD and slope.  
**[F4] [MLM]** : Re-measure the second point or aim then measure the new second point (remain the same first point).

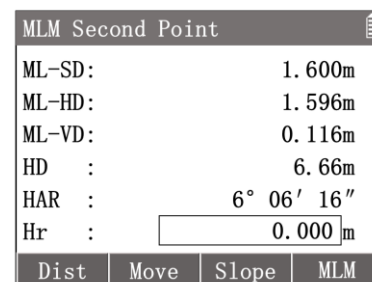

When press **[F2] [Move]** to transform the start point. Workspace displays the coordinates of the last measured point.

**[F3] [NO]** : Back to the last MLM result and remain the old start point.

**[F4] [YES]** : Set the last second point as new start point and begin new MLM.

MLM First Point	
Set to start point?	
N	: 16.066 m
E	: -6.006 m
Z	: 1.016 m
NO   YES	

### 7.3. Remote Height

This application is used to measure a target point where a prism cannot be set up easily, but there is a measurable point directly below (or above) this point.

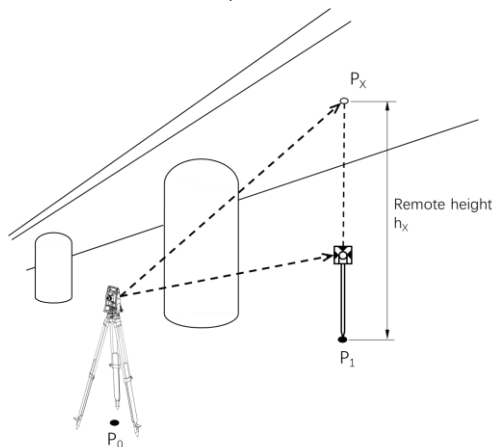

P<sub>0</sub>: Station

P<sub>x</sub>: Target point

P<sub>1</sub>: Measurement point (directly below the target point)

h<sub>x</sub>: Remote height

1. In the measurement interface, press **[M]** to enter **{Main Menu}**.
2. Use the navigation keys to select **<3.Apps>** and press **[ENT]**, or simply press the numeric key **[3]** to enter **{Applications}**.
3. Press **[3] <3.Remote Height>** to enter **{Remote Height}**.
4. Set up the prism on the measurement point (which is directly below or above the target point). Input the **<hr>**.
5. Aim at the prism and press **[F1] [Dist]** to trigger the distance measurement.

Applications	
1.	Offset
2.	Miss. Line Measure
3.	Remote Height
4.	Area
5.	Resection
6.	Reference Line

Remote Height	
HD	: ----- m
ZA	: 66° 16' 16"
HAR	: 166° 16' 16"
Hr	: <input type="text" value="0.000"/> m
<b>Dist</b>	

- Rotate the telescope vertically and aim at the target point, then Press **[F4] [RHM]** . Workspace displays the height and coordinates of the target point.

**<hx>** : The height of target point. The value is updated in real time by rotating the telescope vertically.

**<HD>** : HD of the target point.

**<ZA>** : ZA of the target point.

**<HAR>** : HA of the target point.

**[F2] [Stop]** : Back to previous interface.

**[F3] [Rec]** : Record the target point coordinates.

Remote Height	
HD :	10.006m
ZA :	66° 16' 16"
HAR :	166° 16' 16"
Hr :	<input type="text" value="1.500"/> m
Dist RHM	

Remote Height	
hx :	12.816m
HD :	10.006m
ZA :	126° 19' 43"
HAR :	166° 16' 16"
Stop Rec	

## 7.4. Area

This application is used to calculate an area enclosed by max. 50 vertices and straight edges. The vertice coordinates can be measured, selected from memory or input manually.

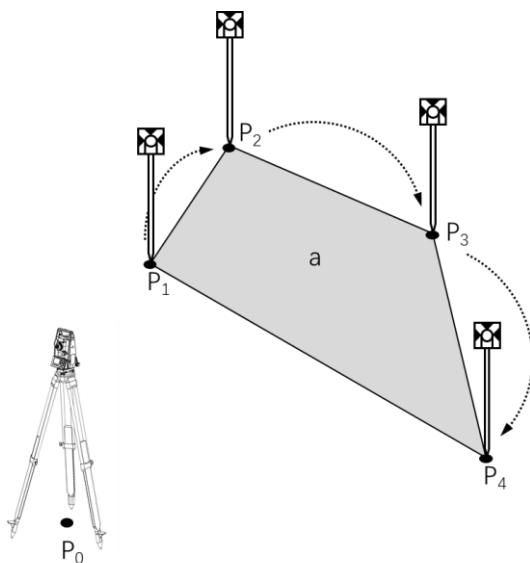

- P<sub>0</sub>: Station
- P<sub>1</sub>: Start point 1#
- P<sub>2</sub>: Target point 2#
- P<sub>3</sub>: Target point 3#
- P<sub>4</sub>: Target point 4#
- a: Area closed by P<sub>1</sub>-P<sub>4</sub>

All the target points must be distributed continuously in clockwise or anti-clockwise order, otherwise the area calculation will not give the correct result.

- In the measurement interface, press **[M]** to enter **{Main Menu}**.
- Use the navigation keys to select **<3.Apps>** and press **[ENT]**, or simply press the numeric key **[3]** to enter **{Applications}**.
- Press **[4] <4.Area>** to enter **{Area Calculate}**. Workspace displays the list of target points.

**[F1] [Dist]** : Enter in the point measurement interface to measure a target point.

Applications
1. Offset
2. Miss. Line Measure
3. Remote Height
4. Area
5. Resection
6. Reference Line

**[F3] [List]** : Enter **{Known Point List}** to select a known point as the target point.

**[F4] [P1/2]** : To 2<sup>nd</sup> page of softkeys.

2<sup>nd</sup> page of softkey **[F2] [Input]** : Enter **{New Point}** to create a target point by manual input.

Any target point can be created by one of the tree methods.

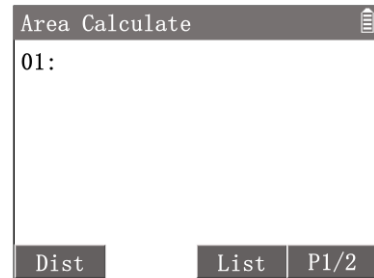

Press **[F1] [Dist]** to measure a target point.

Aim at the target point then press **[F1] [Dist]** to measure it. Press **[F4]**

**[Rec]** to record the coordinates then press **[F3] [OK]** back to the point list interface. The point serial number will plus 1 automatically.

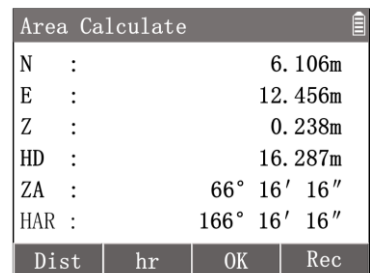

After measuring or inputting some target points, the list will display all the point records.

Press **[▲]** to highlight the last point record, then press **[F4] [P1/2]** to 2<sup>nd</sup> page of softkeys, **[F2] [Delete]** will be available to delete the last point.

When the point records in the list are 3 or more, **[F2] [CAL]** will be available.

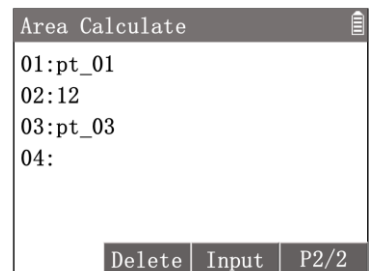
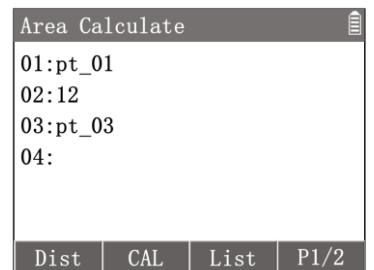

After getting all the target points,

Press **[F2] [CAL]** to calculate and display the area result.

**[F2] [Cont]** : back to the point list and continue to add more points.

**[F3] [END]** : Exit the program.

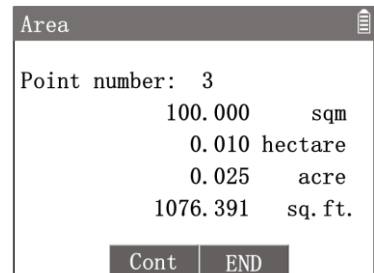

## 7.5. Resection

This application is used to determine the station (instrument) coordinates by measuring and backcalculating some known points. The calculation requires between 2 and 5 known points.

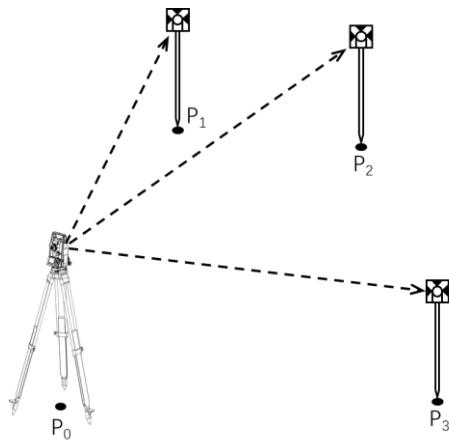

P<sub>0</sub>: Station  
P<sub>1</sub>: Known point 1#  
P<sub>2</sub>: Known point 2#  
P<sub>3</sub>: Known point 3#

1. In the measurement interface, press **[M]** to enter **{Main Menu}**.
2. Use the navigation keys to select **<3.Apps>** and press **[ENT]**, or simply press the numeric key **[3]** to enter **{Applications}**.
3. Press **[5]** **<5.Resection>** to enter **{Resection}**. Workspace guide to get the point 1 coordinates. Two methods can be used.  
**[F2] [List]** : Enter **{Known Point List}** to select a known point as the target point.  
**[F4] [Input]** : Enter **{New Point}** to create a known point by manual input.
4. After getting point 1 coordinates, press **[F3] [OK]** to the point 2 interface.
5. Enter point 2, point 3, etc. up to 5.  
After getting point 2, **[F1] [Meas]** will be available.
6. Press **[F1] [Meas]** then Press **[ENT]** to confirm points and enter resection measurement interface.

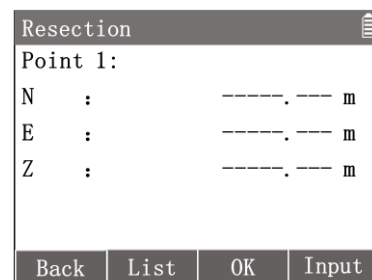
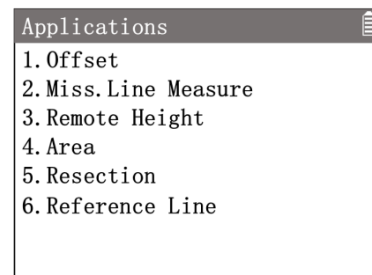

Resection measurement can be implemented by two methods.

**[F1] [Dist]** : Enter distance method.

**[F2] [MeasA]** : Enter angle method.

Distance method will measure the distance and the angle of known point.

Angle method will measure the angle only.

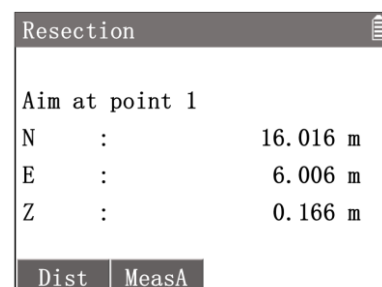

The distance method requires at least two known points to calculate the result. Angle method requires at least three known points for calculation.



**Distance Method** : Press **[F1] [Dist]** to enter distance method interface.  
Aim at the known point 1 and press **[F1] [Dist]** to trigger the measurement.

**[F1] [Dist]** : Remeasure the point.

**Angle Method** : Press **[F2] [MeasA]** to enter angle method interface.  
Aim at the known point then press **[F3] [YES]** to measure and record the angle data.

**[F3] [YES]** : Record the data and enter the next point measurement.

**[F4] [NO]** : Back to last step.

Repeat the steps to measure all the known points.

While the known points measured are enough to calculate the result,

**[F2] [CAL]** will be available. Press **[F2] [CAL]** to enter in **{Resection Result}**.

Workspace displays the calculated coordinates of station.

Press **[F4] [P1/2]** to 2<sup>nd</sup> page of interface, Workspace display the residuals of each direction.

**<PointID>** : Station point name.

**<hi>** : Instrument height.

**<N>** : Station coordinates N.

**<E>** : Station coordinates E.

**<Z>** : Station coordinates Z.

**<dN>** : The residual of N.

**<dE>** : The residual of E.

**<dZ>** : The residual of Z.

**[F1] [AddPT]** : Add known point and perform resection again.

**[F2] [SetSTN]** : Set the calculated result as the current station coordinates.

**[F3] [Rec]** : Record the calculated result.

**[F4] [P1/2]** : Turn to the 2<sup>nd</sup> page of interface.

Resection	
Point 1:	16
SD :	16.016m
ZA :	66° 16' 16"
HAR :	166° 16' 16"
hr :	<input type="text" value="0.000"/> m
Dist	YES NO

Resection	
Point 2:	24
ZA :	76° 16' 16"
HAR :	66° 16' 16"
hr :	<input type="text" value="0.000"/> m
	YES NO

Resection Result	
PointID:	<input type="text" value="26"/>
hi :	<input type="text" value="1.500"/> m
N :	-26.060 m
E :	1.016 m
Z :	1.606 m
AddPT	SetSTN Rec P1/2

## 7.6. Reference Line

This application can easily stake out or checking of lines for buildings, sections of road, simple excavations, etc. After defining a reference line by two points, the user can use the programs to stake out or measure based on the reference line.

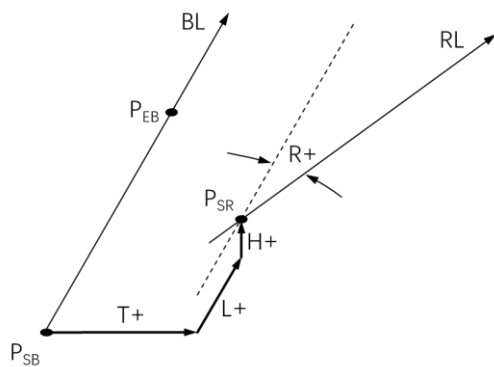

P<sub>SB</sub>: Start base point  
 P<sub>EB</sub>: End base point  
 BL: Base line  
 T+: T-Offset  
 (Transverse offset)  
 L+: L-Offset  
 (Longitudinal offset)  
 H+: H-Offset  
 (Height offset)  
 P<sub>SR</sub>: Start reference point  
 R+: Rotate angle  
 RL: Reference line

1. In the measurement interface, press **[M]** to enter **{Main Menu}**.
2. Use the navigation keys to select **<3.Apps>** and press **[ENT]**, or simply press the numeric key **[3]** to enter **{Applications}**.
3. Press **[6]** **<6.Reference Line>** to enter **{Reference Line}**.
4. Perform pre-settings.

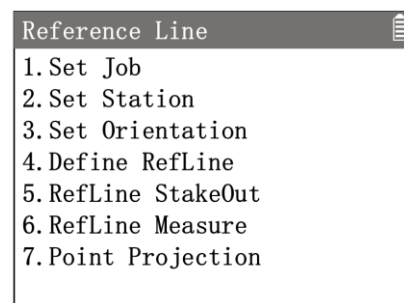
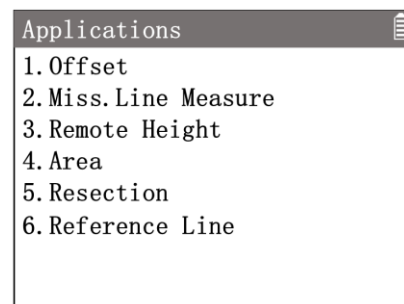

### Define Reference Line:

Reference line is defined by a base line or offset base line. The base line is defined by two base points. The base point can be measured, selected from memory or input manually.

1. Press **[4]** **<4.Define RefLine>** to enter in **{Define Ref. (Start Pt)}**. Define the start base point by one of three methods.

**[F1] [Dist]** : Aim at the start point then press to measure it.

**[F2] [List]** : Enter **{Known Point List}** to select a known point as the start point.

**[F3] [Input]** : Enter **{New Point}** to create a start point by manual input.

After entering the start point, press **[F4] [Rec]** to Record the coordinates. Enter in **{Define Ref. (End Pt)}**

2. Define the end base point by one of three methods in **{Define Ref. (End Pt)}**. Press **[F4] [Rec]** to Record the coordinates. Enter in **{Define Refline(1)}** to check the base line.

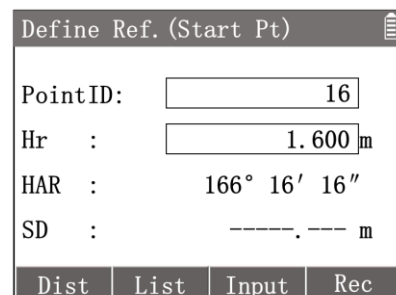

⟨**HA**⟩ : Horizontal direction of the base line.

⟨**HD**⟩ : HD between the start and end point.

⟨**VD**⟩ : VD between the start and end point.

⟨**Slope**⟩ : Slope of the base line.

- Press **[F4] [P1/2]** to enter in **{Define Refline(2)}**. The reference line can be offset either longitudinally, transversely or vertically to the base line, or be rotated around the start base point as required.

⟨**T-Offset**⟩ : Transverse (parallel) offset of the base line. Rightward is positive.

⟨**L-Offset**⟩ : Longitudinal offset of the start base point. Direction from the start point towards the end is positive.

⟨**H-Offset**⟩ : Height (vertical) offset of the start base point. Upward is positive.

⟨**Rotate**⟩ : Horizontally rotate angle of the base line based on the start point.

- After inputting the offset values, press **[F1] [OK]** to confirm the reference line and back to **{Reference Line}**.

Define Ref. (End Pt)	
PointID:	<input type="text" value="17"/>
Hr :	<input type="text" value="1.600"/> m
HAR :	116° 16' 16"
SD :	----- . --- m
<input type="button" value="Dist"/> <input type="button" value="List"/> <input type="button" value="Input"/> <input type="button" value="Rec"/>	

Define RefLine(1)	
HA :	287° 06' 18"
HD :	2.691m
VD :	-0.070m
Slope:	2.5918%
<input type="button" value="OK"/> <input type="button" value="P1/2"/>	

Define RefLine(2)	
T-Offset:	<input type="text" value="0.000"/> m
L-Offset:	<input type="text" value="0.000"/> m
H-Offset:	<input type="text" value="0.000"/> m
Rotate:	<input type="text" value="0.0000"/> °
<input type="button" value="OK"/> <input type="button" value="P2/2"/>	

### Reference Line Stakeout:

The program calculates the stakeout point coordinates by offset values of the reference line, then stake out the target point.

After defining a reference line.

- Press **[5] <5.RefLine Stakeout>** to enter in **{RefLine Stakeout}**.  
Input the stakeout point's offset values of the reference line.

⟨**T-Offset**⟩ : Transverse offset of the reference line. Right side is positive.

⟨**L-Offset**⟩ : Longitudinal offset of the start reference point. Direction from the start point towards the end is positive.

⟨**H-Offset**⟩ : Height (vertical) offset of the reference line. Above is positive.

- Press **[F3] [OK]** to calculate and display the coordinates of stakeout point.
- Press **[F1] [StOut]** to enter in **{Stake Out}** program. Following the guide to stake out the target point. Refer to [Stake Out](#).

**[F3] [Rec]** : Record the target point coordinates.

RefLine StakeOut	
T-Offset:	<input type="text" value="0.000"/> m
L-Offset:	<input type="text" value="0.000"/> m
H-Offset:	<input type="text" value="0.000"/> m
<input type="button" value="OK"/>	

RefLine StakeOut	
N :	6.016 m
E :	1.660 m
Z :	16.060 m
hr :	<input type="text" value="1.600"/> m
<input type="button" value="StOut"/> <input type="button" value="Rec"/>	

Stake Out	
dN :	6.595m
dE :	7.584m
dZ :	-1.391m
HAR :	58° 19' 16"
dHA :	+166° 40' 44"
Dist	List <--> P1/2

### Reference Line Measurement:

The program measures a target point and calculates its offset values of the reference line.

After defining a reference line.

1. Press **[3]** **<Refline Measure>** to enter in **{Refline Measurement}**.
2. Aim at the target point then press **[F1]** **[Dist]** to measure it. Workspace will display the coordinates.
3. Press **[F4]** **[P1/2]** to the 2<sup>nd</sup> interface. Workspace will display the target point's offset values of the reference line.

**[F3]** **[Rec]** : Record the target point coordinates.

RefLine Measurement	
N :	6.016 m
E :	1.660 m
Z :	16.060 m
hr :	<input type="text" value="1.600"/> m
Dist	Rec P1/2

RefLine Measurement	
T-Offset:	-1.106 m
L-Offset:	0.606 m
H-Offset:	-0.020 m
Dist	Rec P2/2

### Point Projection:

The program can project a target point orthogonally onto the reference line and calculate the coordinates and offset of the projection point. The target point coordinates can be measured, selected from memory or input manually.

After defining a reference line.

1. Press **[4]** **<Point Projection>** to enter in **{Point Projection}**.
2. The target point can be inputted directly, selected from **{Known Point list}** or measured. After entering the coordinates, press **[F4]** **[OK]** to calculate the coordinates of projection point on reference line.

**[F1]** **[Dist]** : Aim at the target point then press to measure it.

**[F2]** **[List]** : Enter **{Known Point List}** to select a known point as the start point.

**[F3]** **[Rec]** : Record the target point coordinates.

3. Workspace displays the projection point's coordinates. Press **[F4]** **[P1/2]** to the 2<sup>nd</sup> interface. Workspace will display target point's offset values of the reference line.
4. Press **[F1]** **[StOut]** to enter in **{Stake Out}** program. Following

Point Projection	
Pt to be projected	
N :	<input type="text" value="0.0000"/> m
E :	<input type="text" value="0.0000"/> m
Z :	<input type="text" value="0.0000"/> m
Dist	List Rec OK

the guide to stake out the projection point. Refer to [Stake Out](#).  
**[F3] [Rec]** : Record the projection point coordinates.

Projection Pt	
Projection point:	
N :	6 . 016 m
E :	1. 660 m
Z :	16. 060 m
hr :	<input type="text" value="1. 600"/> m
StOut	Rec P1/2

Refline Measurement	
Pt to be projected:	
T-Offset:	-1. 106 m
L-Offset:	0. 606 m
H-Offset:	-0. 020 m
hr :	<input type="text" value="1. 600"/> m
StOut	Rec P2/2

## 8. File Management



The file manager provides management functions for checking, editing and transmitting data in the instrument.

- ① In the measurement interface, press **[M]** to enter **{Main Menu}**.
- ② Use the navigation keys to select **<1.File>** and press **[ENT]**, or simply press the numeric key **[1]** to enter **{File Manager}**.

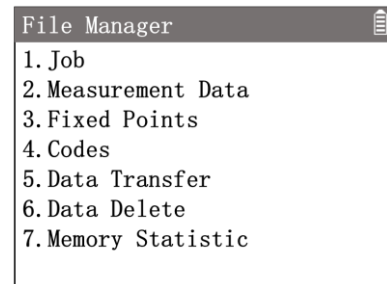

### 8.1. Job Management

Jobs are like folders of different types of data, e.g., measured points, fixed points, codes, calculated results, etc. All the various data of the instrument are stored in jobs. And all applications must work based on a job.

1. In **{File Manager}** press **[1]** **<1.Job>** to enter **{Job Manager}**.  
The workspace list all the jobs available.
2. Use **[▲]** **[▼]** to highlight a job name and press **[ENT]** or **[F4]** **[Select]** to set it as the current job.

**[F1] [view]** : Display the summary of the highlighted job.

**[F2] [New]** : Create a new job.

**[F3] [Delete]** : Delete the highlighted job. The current set job can not be deleted.

**[F4] [Select]** : Selcet the highlighted job as current job.



The system supports up to 30 jobs.

The job named **<Default>** is created automatically by the system.

New job definition consists of job name and user. The name is required. The system will automatically generate the number of records and the date/time of creation.

### 8.2. Measurement Data

The measurement data contains all the recorded data in the instrument internal memory. All the measurement data can be checked, searched or deleted.

1. In **{File Manager}** press **[2]** **<2.Measurement Data>** to enter **{Job Select}**.
2. Use **[◀] [▶]** to toggle the jobs available. Then press **[ENT]** or **[F4] [OK]** to select one and enter **{Measured List}**.
3. Use **[▲] [▼]** to highlight a record and press **[ENT]** or **[F1] [View]** to display the detail information.

**[F1] [view]** : Display the detail of the highlighted record.

**[F2] [Search]** : Enter **{Search}** to input a **<PointID>** then press **[F4] [OK]** to find the related records.

**[F3] [Delete]** : Delete the highlighted record.

Press **[F4] [P1/2]** to 2<sup>nd</sup> page of softkeys,

**[F1] [First]** : Turn to the first page of the list and highlight the first record.

**[F2] [Last]** : Turn to the last page of the list and highlight the last record.

**[F4] [P2/2]** : Turn to the 1<sup>st</sup> page of softkeys.

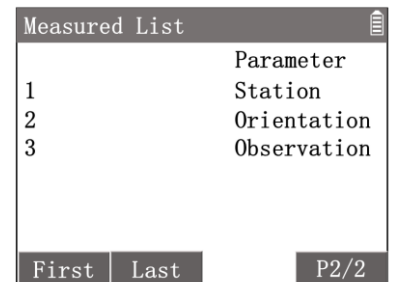
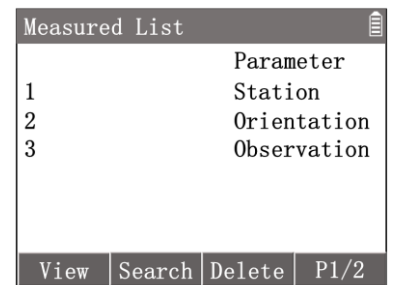
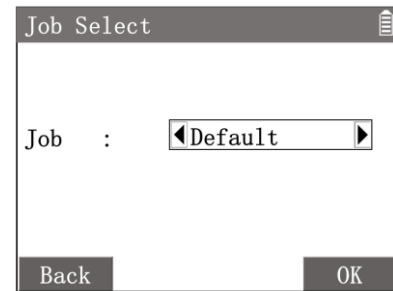

The record in **{Measured List}** list its name and type.

### 8.3. Fixed Points

All the points created by importing or inputing are fixed points.

1. In **{File Manager}** press **[3]** **<3.Fixed Points>** to enter **{Job Select}**.
2. Use **[◀] [▶]** to toggle the jobs available. Then press **[ENT]** or **[F4] [OK]** to select one and enter **{Fixed Point List}**.
3. Use **[▲] [▼]** to highlight a point record and press **[ENT]** or **[F1] [View]** to display the detail information.
4. When checking the detail of the fixed point record, press **[F4] [Edit]** to enter **{New Point}** then can modify it.

**[F2] [New]** : Enter **{New Point}** to create a new fixed point.

**[F3] [Delete]** : Delete the highlighted point record.

Press **[F4] [P1/2]** to 2<sup>nd</sup> page of softkeys,

**[F1] [First]** : Turn to the first page of the list and highlight the first point record.

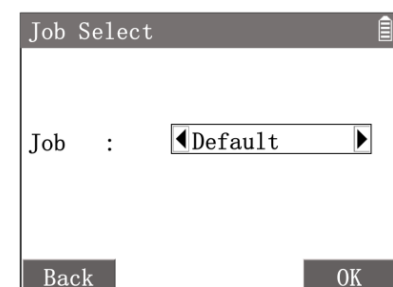

**[F2] [Last]** : Turn to the last page of the list and highlight the last point record.

**[F3] [Search]** : Enter **{Search}** to input a **<PointID>** then press **[F4] [OK]** to find the related point records.

**[F4] [P2/2]** : Turn to the 1<sup>st</sup> page of softkeys.

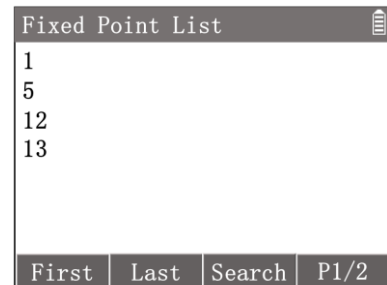
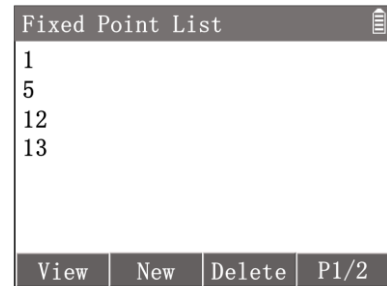

Valid fixed-point record contains at least the **<PointID>** and the coordinates **(N, E, Z)**.

## 8.4. Codes

Codes can be defined manually. All the point can be recorded with a code. Codes help users to manage a large number of points in groups or categories.

1. In **{File Manager}** press **[4] <4.Codes>** to enter **{Code List}**.
2. Use **[▲] [▼]** to highlight a code.

**[F1] [Last/First]** : Turn to the last/first page of the list and highlight the last/first code.

**[F2] [Search]** : Enter **{Search}** to input a **<Code>** then press **[F4] [OK]** to find the related codes.

**[F3] [Delete]** : Delete the highlighted code.

**[F4] [New]** : Enter **{New Code}** to create a new code.

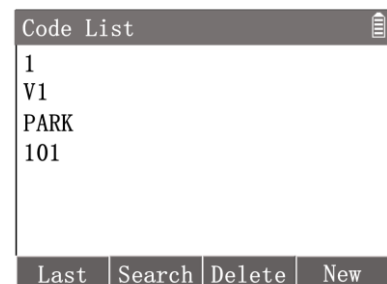

## 8.5. Data Transfer

The instrument has a USB port, which support USB storage device to perform data transfer. A qualified USB stick is recommended.

In **{File Manager}** press **[5] <5.Data Transfer>** to enter **{Data Transfer}**.

Open the waterproof cover on the instrument's USB port and insert the USB flash drive into it, taking care of the orientation.

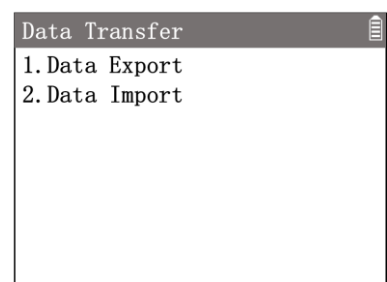



### Data Export:

Copy the data from the instrument internal memory to the USB stick.

In **{Data Transfer}** press **[1] <1.Data Export>** to enter **{Data Export}**.

**<To>** : Copy to USB stick

**<DataType>** : The data type to be copied, **Measurement, Fixed Point** or both.

**<SelectJob>** : Select a job to be transferred.

**<FileName>** : Input a file name which will be create.

**<Format>** : Select a file format which will be create.

**[F3] [List]** : Enter **{Job Manager}** to select a job.

**[F4] [OK]** : Perform the transfer. The data file will create and copy to the default folder named Jobs in the USB stick.

The system support four types data file format, **TXT, R20, CASS, R20** format is the specialized format for the data conversion software **Cube-link** or **Cube-manager**. *Data conversion*

When the **<Format>** is **<TXT>**, Press **[F4] [OK]** will enter in **{Text Formatting 1/2}** to set the text formatting.

**<Delimiter>** : Choose how to separate the numbers within each row of point data, the options are **Comma, Spacing, Tab** and **Semicolon**.

**<Leng.Unit>** : Select the unit of length for the point coordinates, options include **m, feet** etc.

**<Header>** : Whether to add a file header in the first row, i.e., a description of the meaning of each column of data.

**<First...Fifth>** : Defines the meaning of the text in each column, i.e., the sequence text meaning of a row of point data, optionally **Point ID, East, North, Height, Code, None**.

**[F1] [Reset]** : Reset all options to default format.

**[F3] [OK]** : Perform the transfer. The TXT file will create and copy to the default folder named Jobs in the USB stick.

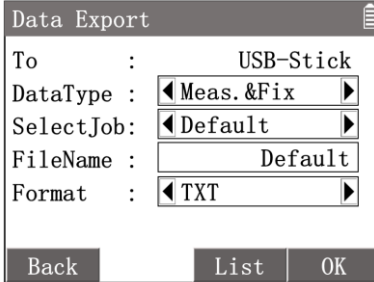
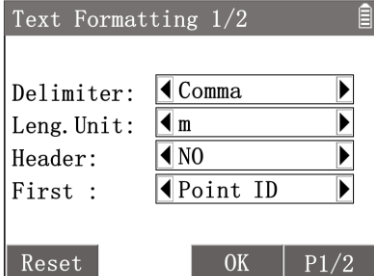
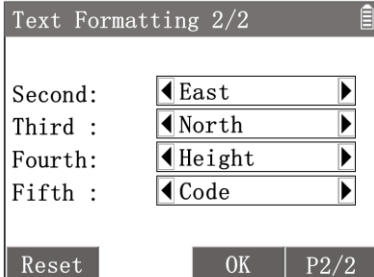
### Data Import:

Copy the data from the USB stick to the instrument internal memory.

① In **{Data Transfer}** press **[2] <2.Data Import>** to enter **{Data Import}**.

② Press **[F4] [OK]** to enter **{Select File}**.

③ Use **[▲] [▼]** to highlight a file and press **[ENT]** or **[F4] [OK]** to enter **{Define Job Name}**.

④ The default job name is same as the file name. Job name can be re-defined manually. After defining the job name, Press **[F4] [OK]** to enter **{Text Formatting}**.

⑤ The setting of formatting is same as the setting in TXT export. Set the sequence of point data following the file's text formatting. Then press **[F3] [OK]** to perform the transfer. The file data will copy to the defined job and all records will be created as fixed points.

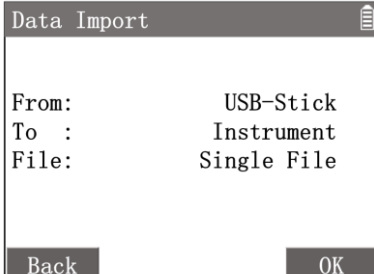

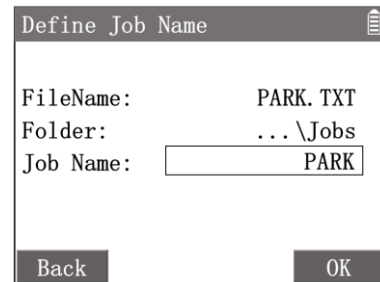
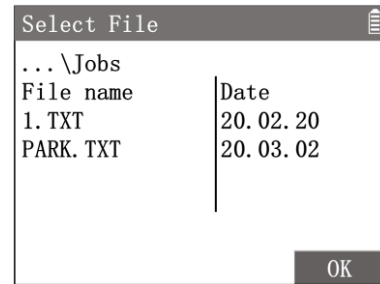

The instrument automatically searches the data files in the Jobs folder in the root directory of the USB stick. The import file must have the extension "**TXT**".

As a media of measurement data, the USB stick is an important equipment. Some important notes need to be followed when using it to avoid losing important measurement data or causing damage to the instrument or the USB stick itself:

- We recommend the use of industry standard USB sticks and cannot be held responsible for data loss or any other errors caused by users using non-standard USB sticks.
- Avoid removing the USB stick during import and export transfer.
- Too much data on the USB stick may cause operation to lag.
- Both the USB port and the USB stick need to be kept dry and clean. Any contact with liquids needs to be completely dry and clean before operation.
- Avoid dropping the USB stick or giving it a violent shock.
- Store and use the USB stick within the specified temperature range.

About the temperature range refer to [Technical Data](#).

## 8.6. Data Delete

Delete jobs, or delete part of data in a job.

1. In **{File Manager}** press **[6]** **<6.Data Delete>** to enter **{Data Delete}**.
2. Use **[▲]** **[▼]** to highlight a item then use **[◀]** **[▶]** to toggle the options available.

**<DataType>** : The datatype to be deleted, can be **Job**, **Measurement** or **Fixed Point**.

**<Job>** : Select **Single Job** or **All Jobs** to operate.

**<SelJob>** : If above **Single Job** was activated, a job name can be selected.

**[F4]** **[Delete]** : Erase the data selected by above options.

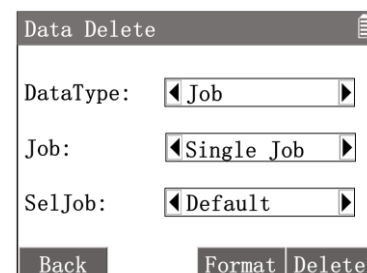

**[F3] [Format]** : Erase all the data in internal memory.

Data deletion is not recoverable, please execute with caution.

## 8.7. Memory Statistic

Summary the data by different jobs in the internal memory.

In **{File Manager}** press **[7]** **<7.Memory Statistic>** to enter **{Memory Statistic}**.

**<Job>** : Use **[◀]** **[▶]** to select the job to be summarized.

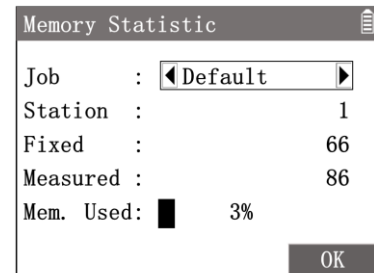

## 9. Instrument Settings

All customisable parameters and options for the instrument and system can be configured in the instrument settings.

1. In the measurement interface, press **[M]** to enter **{Main Menu}**.
2. Use the navigation keys to select **<4.Setting>** and press **[ENT]**, or simply press the numeric key **[4]** to enter **{Setting}**.

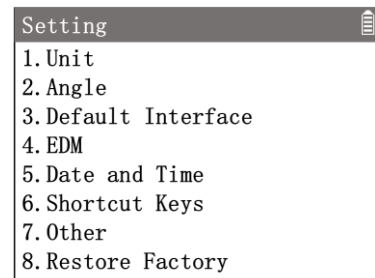

### 9.1. Unit Settings

1. In **{Setting}** press **[1]** **<1.Unit>** to enter **{Unit Setting}**.
2. Use **[▲]** **[▼]** to highlight a item then use **[◀]** **[▶]** to toggle the options available.
3. Press **[F3]** **[OK]** to confirm the settings.

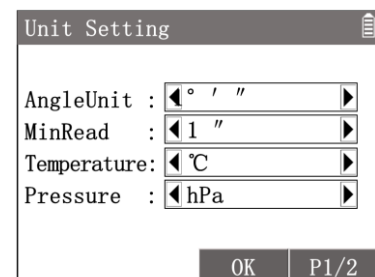

**<AngleUnit>** : Set the unit of angle.

- ° ' " : 0°00'00" – 360°00'00"
- **gon** : 0gon – 400gon
- **mil** : 0mil - 6400mil
- ° : 0° – 360°

**<MinRead>** : Set the minimum reading of angle.

- **<AngleUnit>** ° ' " : **1"/5"/10"**
- **<AngleUnit>** **gon** : **0.1mgon/0.5mgon/1mgon**
- **<AngleUnit>** **mil** : **0.01/0.05/0.1**
- **<AngleUnit>** ° : **0.0001/0.0005/0.001**

**<Temperature>** :Set the unit of air temperature: °C/°F.

**<Pressure>** : Set the unit of atmospheric pressure: **hPa/mbar/mmHg/inHg**

**<DistUnit>** : Set the unit of distance and coordinates: **m/US-ft (ft)/INT-ft(fi)/ft-in1/16**

**<Decimals>** :Set the number of decimal places of distance and coordinates:**3/4**

## 9.2. Angle Settings

1. In **{Setting}** press **[2]** **<2.Angle>** to enter **{Angle Setting}**.
2. Use **[▲]** **[▼]** to highlight a item then use **[◀]** **[▶]** to toggle the options available.
3. Press **[F4]** **[OK]** to confirm the settings.

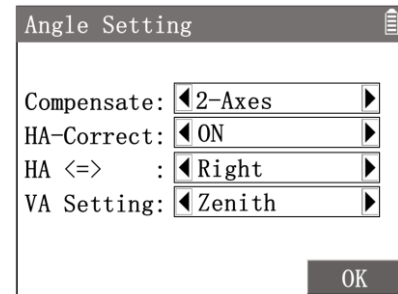

**<Compensate>** :Set the function of tilt compensator: **2-Axes/OFF/1-Axis**

Refer to [Tilt Compensation](#).

In the measurement interface of angle measurement mode, press **[F1]** **[Level]** of 2<sup>nd</sup> page of softkey to enter **{Level & Plummet}** to set the compensation. Press **[★]** in the measurement related interfaces also can select then enter **{Level & Plummet}**.

**<HA-Correct>** : Set the collimation error auto correction on HA: **ON/OFF**

**<HA <=>>** : Set the incremental direction of the HA.

- **Right** : HA increases on rotating clockwise. The HA displays HAR.
- **Left** : HA increases on rotating anticlockwise. The HA displays HAL.

**<VA Setting>** : Set the mode of VA.

- **Zenith** : The VA is 0 when aiming at the zenith.
- **HZO** : The VA is 0 when aiming horizontally. Positive VA when rotated upwards.
- **Slope %** : Display the VA with slope in percent. Positive VA when rotated upwards.

## 9.3. Default Interface

1. In **{Setting}** press **[3]** **<3.Default Interface>** to enter **{Default Interface}**.
2. Use **[▲]** **[▼]** to highlight a item then use **[◀]** **[▶]** to toggle the options available.
3. Press **[F4]** **[OK]** to confirm the settings.

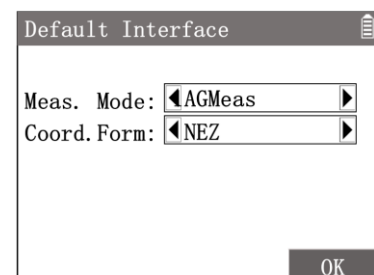

**<Meas.Mode>** : Set the first measurement interface after power on.

- **AGMeas** : Angle measurement interface.
- **DTMeas** : Distance measurement interface.
- **CoordMeas** : Coordinates measurement interface.

**<Coord.Form>** : Set the display format of coordinates.

- **NEZ** : Coordinates order North, East, Height.
- **ENZ** : Coordinates order East, North, Height.

## 9.4. EDM Settings

The EDM settings define the parameters related to Electronic Distance Meter, which can be set by the users according to the actual measurement needs and the environment.

Any setting of the EDM parameters may have an effect on the actual distance measurement data and thus affect the measurement results. Be careful when entering the parameters, and always check that the EDM settings are appropriate before the measurement is taken to avoid unnecessary errors in the results.

1. In **{Setting}** press **[4]** **<4.EDM>** to enter **{EDM Setting}**. Press **[★]** in the measurement related interfaces then select **<2.EDM Set>** also can enter **{EDM Setting}**.
2. Use **[▲]** **[▼]** to highlight a item then use **[◀]** **[▶]** to toggle the options available.
3. Press **[F3]** **[OK]** to confirm the settings.

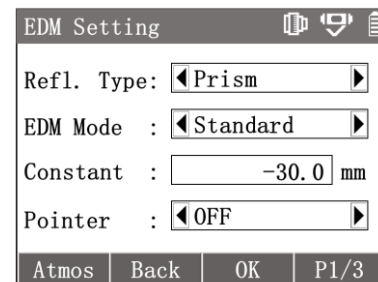

**<Refl.Type>** : Set the type of target on distance measuring.

- **Prism** : The target is reflector prism.
- **Tape** : The target is reflector tape.
- **NonPrism** : The target is object itself, i.e., reflectless.

**<EDM Mode>** : Set the mode of EDM working.

- **Standard** : Fine mode, default high precision mode.
- **Fast** : Fast mode with increased measurement speed but possibly slightly reduced accuracy.
- **Track** : Continuous measuring mode.
- **Repeat** : Repeat measuring until manually stop.
- **Average** : After measuring defined times on standard mode, average the results.

**<Constant>** : Input the prism constant when **<Refl.Type>** is **Prism**.

The unit is mm and input range from -999.9 to 999.9.

**<Pointer>** : To emit a laser beam coaxial to the telescope, creat a visible red spot on the near target to indicate the current aiming point position: **OFF/ON**

**[F1] [Atmos]** : Enter **{Atmospheric}** to set the parameters related to atmosphere.

**<PPM>** : Automatically calculated multiplying constant (mm/km,  $10^{-6}$ ) according on the parameters below.

**<Temp>** : The air temperature of measuring.

**<Pressure>** & **<Elev>** : The local air pressure and elevation. Two values are linked, just set either one.

**<Refract>** : Atmospheric refractive index.

**[F2] [PPM0]** : Reset all parameters to default values:

**20°C, 1013.25hPa, 0m, 0.13**

Distance measurements are directly influenced by atmospheric conditions on the laser path. Atmospheric corrections are required for precision distance measurements and involved into the VD/HD calculations.

Refer to [Atmospheric Correction, Refraction and Earth Curvature Correction](#).

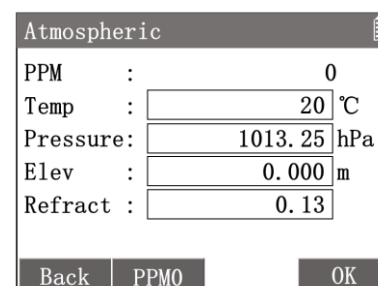

2<sup>nd</sup> page of softkey **[F1] [Scale]** : Enter **{Projection Scale}**.

⟨**Factor**⟩ : Set the projection correct scale value.

**[F2] [PPM0]** : Reset the factor to default value 1.

**[F4] [OK]** to confirm the setting.

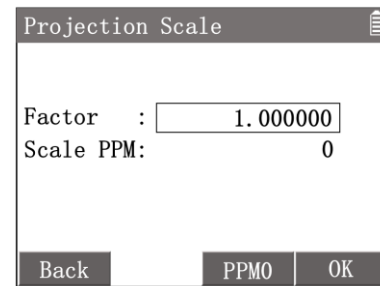

2<sup>nd</sup> page of softkey **[F2] [Signal]** : Enter **{Signal}** to test and display the EDM signal (reflected return light intensity) in steps of 1%.

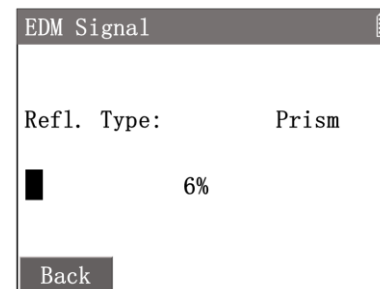

This function can help to improve the aim accuracy when the target prism cannot be accurately identified.

3<sup>rd</sup> page of softkey **[F1] [PPM]** : Enter **{Input PPM}** to set additional multiplying and adding constants to correct the distance result directly when necessary.

⟨**Mul.PPM**⟩ : Input a multiplying constant (mm/km,  $10^{-6}$ ) for distance measuring.

⟨**AddConst**⟩ : Input an adding constant (mm) for distance measuring.

**[F2] [Reset]** : Reset all input values to 0.

**[F4] [OK]** to confirm the input values.

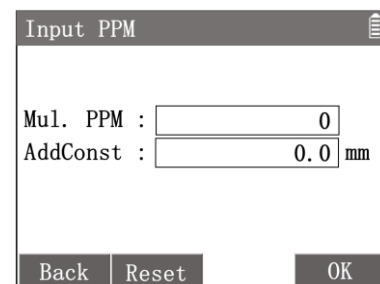

3<sup>rd</sup> page of softkey **[F2] [Times]** : Enter **{Average Times}** to set the number of measuring times of ⟨**EDM Mode**⟩ **Average** . The default times is 3.

**[F4] [OK]** to confirm the input value.

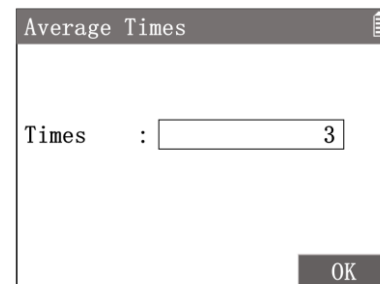

## 9.5. Date and Time Setting

1. In **{Setting}** press **[5]** **<5.Date and Time>** to enter **{Date&Time Setting}**. Set the data and time
2. Use **[▲]** **[▼]** to highlight a item then input a new value.
3. Press **[F4]** **[OK]** to confirm the settings.

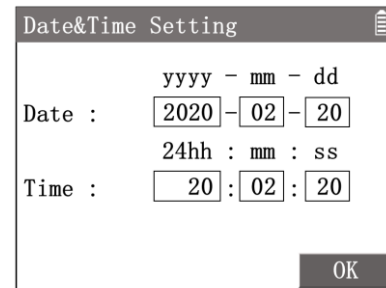

## 9.6. Shortcut Keys

1. In **{Setting}** press **[6]** **<6.Shortcut Keys>** to enter **{Shortcur Keys}**.
2. Use **[▲]** **[▼]** to highlight a item then press **[ENT]** to enter the setting.

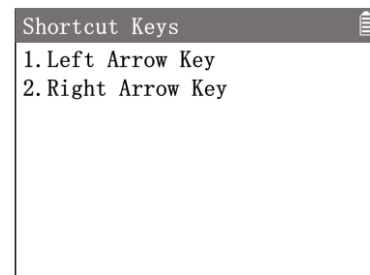

There are two shortcut keys whose functions can be defined by users. Two shortcut keys are the arrow keys **[←]** and **[→]**. A key's function can be set as a one-click access application pre-defined. Eight applications can be selected.

### For Example:

1. In **{Shortcur Keys}** press **[1]** **<1.Left Arrow Key>** enter **{Left Arrow Key Setting}**.
2. Press **[7]** **<7.Area>** to set the left shortcut key function as the application **Area**.
3. In the measurement interface, press **[←]** can directly enter **{Area Calculate}**.

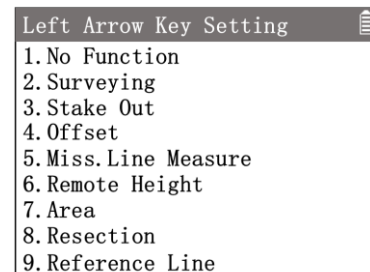

## 9.7. Other Settings

1. In **{Setting}** press **[7]** **<7.Other>** to enter **{Other Setting}**.
2. Use **[▲]** **[▼]** to highlight a item then use **[←]** **[→]** to toggle the options available.
3. Press **[F3]** **[OK]** to confirm the settings.

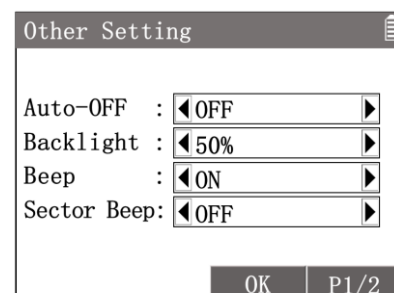



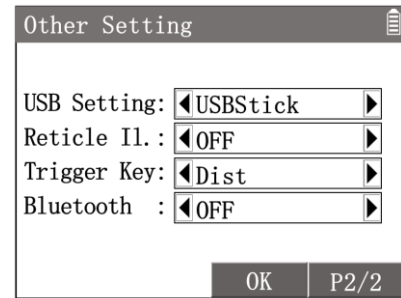

⟨**Auto-OFF**⟩ : The instrument will automatically switch off after 15 minutes without any operation.

- **OFF** : Inactive.
- **10/20/30 Min.** : The instrument will automatically switch off after **10/20/30** minutes without any operation.

⟨**Backlight**⟩ : LCD display brightness setting: **0%** to **100%** in 10 steps.

⟨**Beep**⟩ :Set the beep sound **ON** or **OFF**.

⟨**Sector Beep**⟩ :Set the sector beep sound **ON** or **OFF**. **On** : When the HA value is within  $\pm 5^\circ$  of the quadrant angles  $0^\circ$ ,  $90^\circ$ ,  $180^\circ$ ,  $270^\circ$ , etc., the buzzer emits a short continuous beep sound.

⟨**USB Setting**⟩ : The default function of USB port is support USB stick.

⟨**Reticle Il.**⟩ : Switch the illumination for the reticle **OFF** or set a brightness level **G1-4**.

⟨**Trigger Key**⟩ : Set the function of trigger key.

- **Dist** : Touch the trigger key will trigger the function of softkey **[Dist]** .
- **Dist&Rec** : Touch the trigger key will trigger the function of softkey **[All]** ( **[Dist]** then **[Rec]** ).
- **OFF** : Inactive.

⟨**Bluetooth**⟩ : Set the bluetooth function **ON** or **OFF**. **On** :  will display on the status bar.

## 9.8. Restore Factory

1. In {Setting}press [8] ⟨8.Restory Factory⟩ .
2. use [◀] [▶] to select YES or NO then press [ENT].  
If choose YES, all the settings will be reset to default values or options.

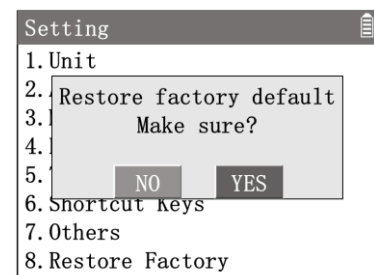

Restoring the factory settings does not delete any measurement data.

To delete the data, refer to [Data Delete](#).

## 10. System Information

1. In the measurement interface, press **[M]** to enter **{Main Menu}**.
2. Use the navigation keys to select **<6.System>** and press **[ENT]**, or simply press the numeric key **[6]** to enter **{System Statiostic}**.

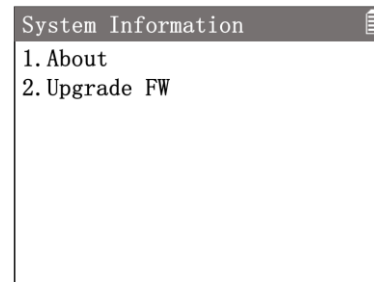

### 10.1. Instrument Information

In **{System Information}** press **[1]** **<1.About>** enter **{About Instrument}**.

Workspace displays the important information of the instrument and system.

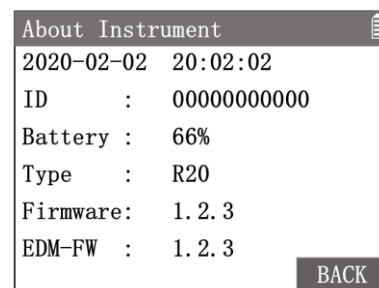

The first line will show the current date and time of the instrument, which will need to be set if there are inaccuracies.

Refer to

*Date and Time* Setting.

**<ID>** : Each instrument will have a unique 10-digit serial number.

**<ID>** should be the same as the serial number on the product label.

**<Battery>** : The remaining battery capacity in reference percent value.

Due to various environmental conditions and different working modes, the remaining battery capacity is only a reference value and cannot accurately indicate the remaining operating time of the instrument.

**<Type>** : The type of the instrument.

**<Firmware>** : The current firmware version number of the instrument.

**<EDM-FW>** : The current firmware version number of the EDM.

### 10.2. System Upgrade

The instrument can add applications or enhance performance by updating its firmware. The latest version of firmware is always recommended.

1. In **{System Information}** press **[2]** **<2.Upgrade FW>** enter **{Upgrade FW}**.
2. Use **[▲]** **[▼]** to highlight a item then press **[ENT]**.

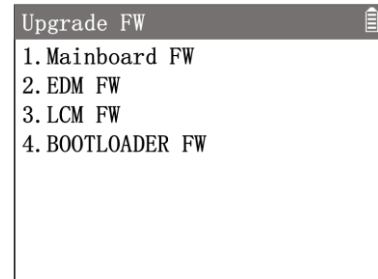

The firmware upgrade is a very important operation and needs to be done with care. The instrument must not be powered down or switched off during the upgrade. The battery needs to be at least 30% charged before uploading and the data in the instrument should be properly backed up.

**Upgrade Procedure:**

1. Copy the correct firmware file to the root directory of the qualified USB stick.  
NOTE: for Mainboard FW, the file must be called "*Update\_R20M1000.fw*". Files named in a different way can not be read by the total station.
2. Insert the USB stick securely into the USB port of the instrument.
3. Enter the **{Upgrade FW}**, use **[▲]** **[▼]** to highlight a correct type FW then press **[ENT]**.
4. A confirming warning message pops up, **[YES]** is highlight, then press **[ENT]**.
5. A power warning message pops up, **[YES]** is highlight, then press **[ENT]**.
6. The instrument automatically updates the firmware. The beep sound continues till the upgrade ends. The display will go down for a period of time during this period.
7. After a successful firmware update, the instrument will automatically reboot.

## 11. Data Transfer and Formats

### 11.1. Bluetooth

The instrument is equipped with Bluetooth 5.0.

The instrument can be used as a Bluetooth slave device to communicate with Bluetooth-enabled mobile phones, pad, notebooks and other master devices for wireless data exchange and operation control.

From version 5.1.xxx of Cube-a it is possible to manage the R20 total station.

On cube-a click *Device* -> *Total Station Communication*, there will be the page shown in next figure.



Select R20 as *Device Type*.

Select *Bluetooth* communication mode in the communication settings interface, and then click *Search*, you will see the page shown below. If you already have a Bluetooth device in the list that you want to connect to, you can click *Stop* to stop searching, and select the name of the Bluetooth device to connect to the Device, click *Connect*. When the Matching dialog box appears, please click “pair” and it could be connected successfully.

NOTE: to successfully connect the total station and the controller check if:

- Bluetooth is ON on the total station (refer to *Other Settings*)
- You have levelled the total station
- You have selected the correct model on cube-a
- You are in the measure page on the total station.
- You will have confirmation that the connection has been successful if the angles' values are shown in the bar status.

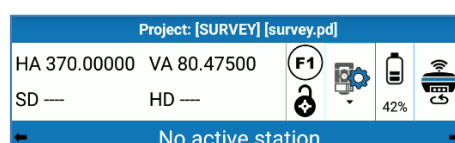

## 11.2. USB Stick

The USB stick can be used to exchange data between the instrument and other devices such as computers, and for firmware upgrades.

The USB stick is supplied with the instrument with a capacity of 4GB and supports up to 32GB. Please use our standard USB stick or a qualified USB stick.

The USB stick can be inserted into the USB port of the instrument to export and import data such as measurement points, fixed points, etc. It is also used to upgrade the firmware of the mainboard, EDM etc. by copying the firmware file onto the USB stick.

## 11.3. Data conversion

The total station allows to download data in the following formats: **TXT, R20, CASS, R20** (refer to [Data Transfer](#)). R20 format files exported from the instrument on a USB stick can be converted to other data format by using the Cube-link or Cube-manager software.

The Cube-link setup is available on USB stick provided with the instrument. It can be installed on a PC and used directly, without need of any license activation.

To import \*.r20 file, open the Topography tab and click on Import fieldbook. Then select R20 as instrument model and follow the guided procedure.

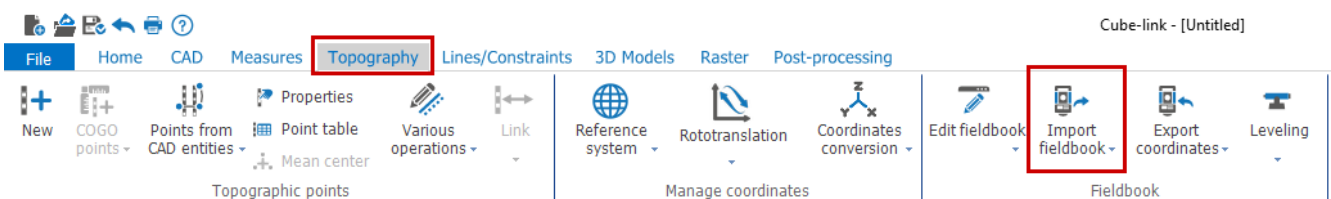

To export a file, click on File/Export and choose the desired format:

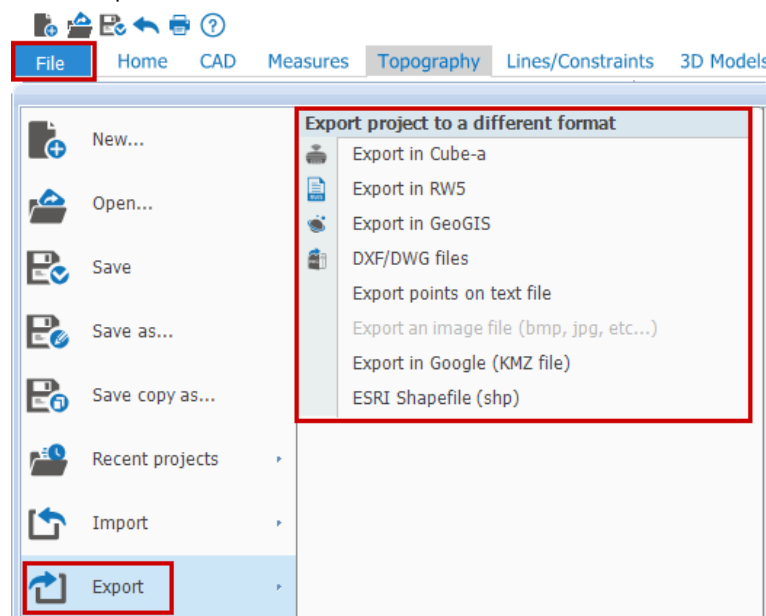

## 12. Calibration

### 12.1. About Calibration

Some error checking and calibration operations can be carried out by the user in the field by running calibration procedures. These procedures need to be carried out carefully and correctly. The detailed procedure is described in the following sections.

The instrument is factory calibrated to exacting specifications, but rapid temperature changes, vibrations or impacts may cause unexpected deviations and a reduction in the accuracy. The user is advised to check and calibrate the instrument frequently.

In the following cases it is highly recommended to check the instrument:

- Before using the instrument for the first time.
- Before each high-precision measurement operation.
- After a bumpy or long transport.
- After long periods of storage.
- After a violent and accidental impact or after falling over.
- The difference between the current temperature and the temperature at the time of the last calibration is greater than 10°C.

In addition to the instrument errors described in this section, some other errors can be calibrated by professional operation. But the calibration process must be carried out either at the factory or an authorised workshop by specialist staff with specialist equipment. Any self-adjustment or calibration will result in unpredictable instrument failure or accuracy problems.

### 12.2. HZ-collimation and V-index

The HZ-collimation (C) is an error due to the fact that the CA of the instrument is not perpendicular to the TA. In the plane formed by the CA and the TA, the angle between the perpendicular line of the TA through the centre of the instrument and the CA is the HZ-collimation Error (C).

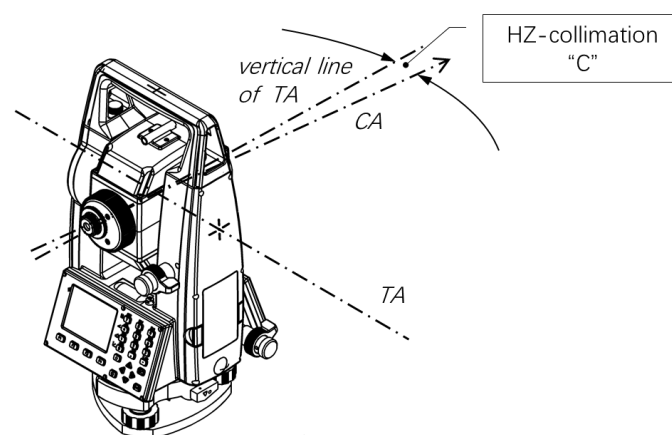

### Determine the HZ-collimation:

1. Set up the tripod and instrument stable.
2. Power on the instrument. Precisely level the instrument under the electronic level indication of **{Level & Plummet}**.
3. In face I, accurately aim at a target about 100m away whose height was similar as the instrument. Record the  $HA_L$ .
4. Turn to face II, accurately aim at the same target again. Record the  $HA_R$ .
5. Calculate the horizontal collimation error C:

$$C = \frac{(HA_L - HA_R \pm 180)}{2}$$

6. If  $|C| > 8''$ , a program calibration is required. Refer to [Program Calibration](#).

### V-index

When the VA (Zenith 0) is  $90^\circ 0' 0''$ , ideally the CA should be precisely perpendicular to the SA. And the actual deviation that exists is the V-index (i).

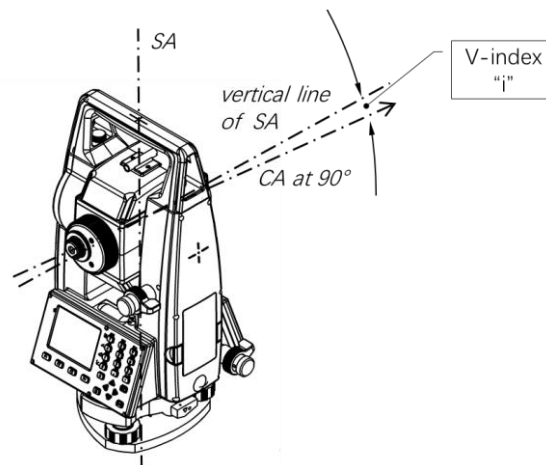

1. Set up the tripod and instrument stable.
2. Power on the instrument. Precisely level the instrument under the electronic level indication of **{Level & Plummet}**.
3. In face I, accurately aim at a target about 100m away whose height was similar as the instrument. Record the  $VA_L$ .
4. Turn to face II, accurately aim at the same target again. Record the  $VA_R$ .
5. Calculate the vertical index error i:

$$i = \frac{(VA_L - VA_R - 360^\circ)}{2}$$

6. If  $|i| > 10''$ , a program calibration is required. Refer to [Program Calibration](#).

## 12.3. Program Calibration

The built-in calibration program can calibrate the following instrument error:

- Hz-collimation
- V-index
- Zero error of the tilt compensator

1. In the measurement interface, press **[M]** to enter **{Main Menu}**.
2. Use the navigation keys to select **⟨5.Calib⟩** and press **[ENT]**, or simply press the numeric key **[5]** to enter **{Calibration}**.

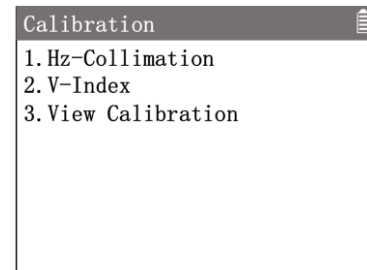

**!** Before calibrating the instrument error, the instrument needs to be accurately levelled under the electronic level indication of the **{Level & Plummet}** interface.

The relationship between the tribrach, tripod and the ground must be stable and avoid any vibration and impact throughout the procedure.

The instrument must be acclimatised to the ambient temperature before the calibration. The acclimatisation time is approximately 2 minutes for every 1°C difference in temperature from the storage environment to the working environment. The total minimum acclimatisation time is at least 20 minutes. During the whole procedure, the instrument must be protected from direct sunlight which can cause overheating on one side of the instrument.

The procedure for calibrating the HA-collimation and the V-index is the same and requires accurate double-faced observation. While calibrating the **V-index**, the instrument will simultaneously calibrate the **Zero error**. During the calibration, the instrument interfaces give clear operating instructions that the user can follow to complete the operation.

#### Calibration Procedure:

1. Set up the tripod and instrument stable.
2. Power on the instrument. Precisely level the instrument under the electronic level indication of **{level & Plummet}**.
3. Enter in **{Calibration}** then choose **⟨1.Hz-collimation⟩** or **⟨2.V-index⟩** to begin a calibration program.
4. In face I, accurately aim at a target about 100m away whose height was similar as the instrument. Press **[F4] [OK]** .
5. Turn to face II, accurately aim at the same target again. Press **[F4] [OK]** .
6. Workspace display the new calculated error value and the old value stored.
7. Press **[F4] [OK]** to confirm the calibration.

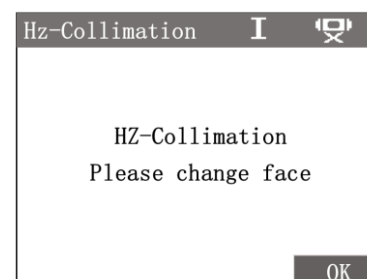
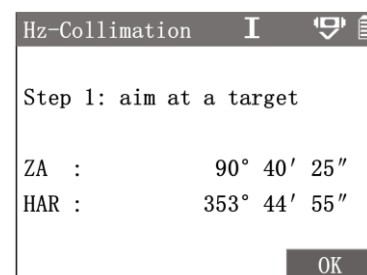



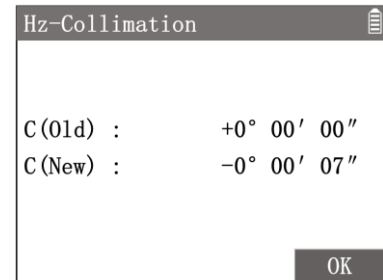
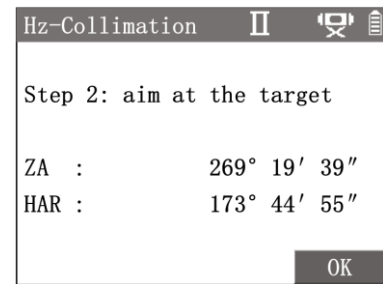

In the last calculated value interface, Press **[ESC]** can quit the calibraton and retain the old parameters.

During the calibration process, the program may pop up a message warning if the operation does not comply with the specifications.

Item	Description
〈VA not suitable for calibration〉	The VA was too far off 90°, or aiming deviation was too big in face II.
〈HA not suitable for calibration〉	Aiming deviation was too big in face II.
〈Out of tolerance! Retained〉	The calculation result is exceeded tolerance due to improper operation; the instrument will retain the original set value.

## 12.4. Mechanical Check and Adjust

### Check and Adjust the Instrument Plate Level and Tribrach Circular Level

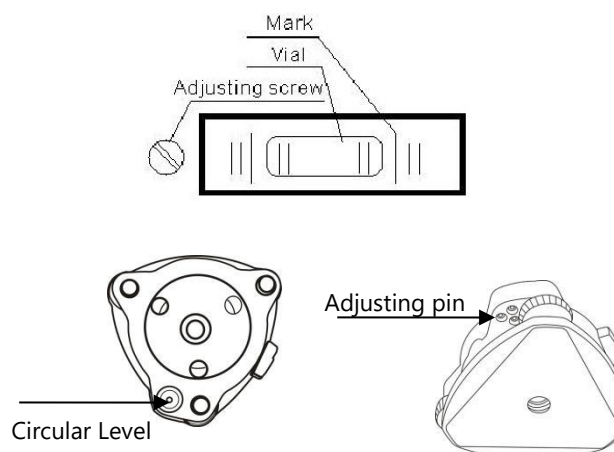

1. Set up the tripod and instrument stable.
2. Power on the instrument. Precisely level the instrument under the electronic level indication of **{Level & Plummet}**.
3. The bubbles of the plate level and the circular level should stop right at the centre.
4. If not, use the adjusting pin to adjust related screws till the bubbles are at the center.

### **Check the Laser Plummet**

The plummet laser spot should be checked on a bright, flat horizontal surface (e.g., on a piece of white paper). The size of the laser spot is related to the condition of the projected surface and the ambient brightness. The average laser spot diameter is approximate 2.5 mm when the instrument is 1.5 m high.

1. Set up the tripod and instrument stable. The instrument height is about 1.5m.
2. Power on the instrument. Level the instrument under the electronic level indication of **{Level & Plummet}**.
3. In **{Level & Plummet}**, adjust the brightness level of the plummet laser to project a clear spot on the ground. Mark the center of the spot.
4. Slowly rotate the instrument horizontally one turn, observe the displacement of the centre of the laser spot.
5. If the displacement is in a clear circular motion and the diameter of the track circle exceeds 3 mm, a calibration is required.

The laser plummet calibration needs to be carried out by an authorised service centre.

## 13. Technical Data

### 13.1. Angle measurement

<b>Accuracy</b>	2"	
<b>Standard deviation</b>	0.6 mgon <sup>1</sup>	
<b>Reading system</b>	Absolute encoder, continuous	
<b>Display resolution</b> (selectable)	<b>Unit</b>	<b>Options</b>
	° ' "	1" /5" /10"
	°	0.0001/0.0005/0.001
	gon	0.0001g/0.0005g/0.001g
	mil	0.01mil/0.05mil/0.1mil

### 13.2. Distance measurement

<b>Characteristics</b>	<b>Principle:</b>	Phase measurement		
	<b>Type:</b>	Red light, coaxial		
	<b>Wavelength:</b>	685nm @25°C		
	<b>Laser class:</b>	3R (NonPrism) / 1 (Prism & Refl. Tape)		
<b>Display resolution</b> (selectable)	<b>Unit</b>	<b>Options</b>		
	m	0.001m/0.0001m		
	US-ft	0.001ft/0.0001ft		
	INT-ft	0.001fi/0.0001fi		
	ft-in <sup>1</sup> / <sub>16</sub>	00.00.01		
<b>Range</b>	<b>Prism<sup>2</sup>:</b>	3.500m		
	<b>EDM mode</b>	<b>Accuracy<sup>3</sup></b>	<b>Measurement time [sec]</b>	
	Standard	2mm+2ppm	0.8	
	Fast	5mm+2ppm	0.5	
	Track	5mm+2ppm	0.3	
	<b>NonPrism<sup>2</sup>:</b>	600m		
	<b>Distance [m]</b>	<b>Accuracy<sup>3</sup></b>	<b>Measurement time [sec]</b>	
	@5-200m	3mm+2ppm	≥0.3	
	@>200m	5mm+2ppm	≥0.3	
	<b>Refl. Tape<sup>2</sup>:</b>	800 m		
	<b>Shortest measuring distance:</b> 0.2 m			

<b>Laser dot size</b>	Distance [m]	Laser dot size, approximately [mm]
	@ 30	8x9
	@ 50	12x15
	@ 100	27x27

### 13.3. General data

<b>Telescope</b>	Type:	Reflector
	Image:	Upright
	Magnification:	30x
	Obj. aperture:	φ 44 mm
	Min. Focus:	1.7 m (5.6 ft)
	Field of view:	1°30' (1.66 gon) 2.6m @100m
	Resolution:	2.8"
	Tube length:	160mm
	Reticle illumination	4 levels
<b>Compensator</b>	Type:	Optoelectronic, dual-axis
	Range:	± 4.0'
	Accuracy:	3"
<b>Level sensitivity</b>	Circular level:	8'/2mm
	Plate level:	30"/2mm
<b>Laser plummet</b>	Type:	Visible red
	Location:	In standing axis of instrument
	Class:	2
	Carrier wave:	635nm
	Accuracy:	± 1,5 mm @ 1,5 m
	Laser spot:	2,5 mm @ 1,5 m
	Max output:	0.7-1.0 mW
<b>Control unit</b>	Display:	LCD, color, 320×240 pixels, LED backlight
	Keyboard:	Alphanumeric - 24 keys
	Position:	In both faces
	Trigger key:	Available
<b>Drives</b>	Type:	Lock horizontal and vertical drives
<b>Internal memory</b>	Readings:	>80.000 points
	Max n. of jobs:	30 jobs
	Export formats:	*.r20, *.sdr, *.txt

<b>Interface</b>	USB:	2.0
	Bluetooth:	5.0
<b>Weight</b>	Instrument:	4.75kg
	Tribrach:	0.70kg
	Internal battery:	0.111kg
	Case with instrument:	9.10kg

**Dimensions**

Instrument:

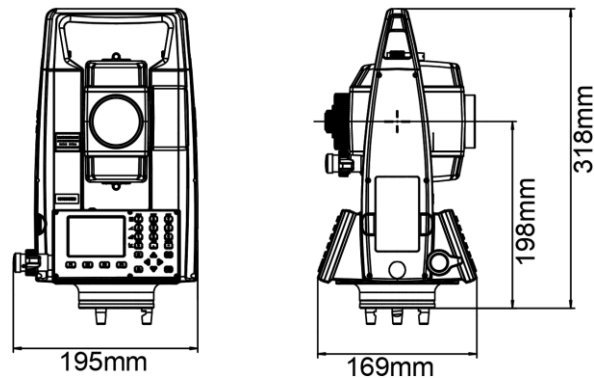

Carrying case (HxWxL): 390x240x490mm

**Power**

Battery type:	Li-Ion
Voltage/Capacity:	7.4V / 2600mAh
Operating time <sup>5</sup> (angle measurement)	22 hours
Oper. time <sup>5</sup> (angle+dist. meas. every 30 s)	19.5 hours
Battery charger:	100/240V, charging time 3h

**Environmental conditions**

Operating temperature:	-20° C to +50° C
Storage temperature:	-30° C to +60° C
Operating humidity:	95%
Waterproof/Dustproof:	IP54
Onboard sensors:	Pressure/Temperature
Pressure correction:	500 hPa to 1500 hPa

**Specifications subject to change without notice**
<sup>1</sup> Standard deviation based on ISO 17123-3

<sup>2</sup> Good condition: cloudy, no haze, visibility about 40km, no heat shimmer, breeze. Under optimal conditions on Kodak Grey Card (90% reflective)

<sup>3</sup> Standard deviation based on ISO 17123-4

<sup>4</sup> Time is referring to a single battery

## 14. Kit components

Open the transport case, remove instrument and check for completeness:

- Total station
- Tribrach
- Battery charger (LC-001)
- Cable of the charger
- Battery (LB-001) × 2
- Objective lens hood
- Tape
- Carrying strap x2
- Rain cover
- Reflective tape/RP30 × 4
- Reflective tape/RP60
- Tools kit
- USB stick with user manual
- Silica gel
- Certification



## 15. Care and Transport

### 15.1. Storage

#### Storage of the Instrument

The instrument is a precision instrument. In order to ensure the function and accuracy, when not in use for a long period of time, the instrument needs to be stored in a dry place without direct sunlight and within a certain temperature range.

About the temperature range refer to [Technical Data](#).

Especially in hot weather when instruments need to be stored in transport vehicles such as cars, it is important to be aware of the limits of the temperature range.

#### Storage of the batteries

- The allowable temperature for storing batteries is -30 °C to +55 °C. The recommended temperature range for storing batteries is -20°C to +30°C in a dry environment.
- Within the recommended storage temperature range, batteries full charged can be stored alone for one year.
- The batteries should be removed from the instrument or charger before storing.
- The battery must be fully recharged again before use after long-term storage.

Always keep batteries away from wet conditions. Wet or waterlogged batteries must be completely dried and checked for proper appearance and voltage before storage and use.

### 15.2. Transport

#### Field Manual Transport

- Place the instrument in its original transport case. Carry it properly by hand or use the original carrying strap.
- Alternatively, by keeping the robust mounting and upward, the instrument can be carried with the tripod's legs splayed across on the shoulder.

Collisions and drops of instruments are avoided wherever possible to ensure the safety of persons and instrument.

#### Transportation by Transport (car, train, ship, plane, etc.)

When transporting, the transport case must be used. Place the instrument in the case and fasten it securely so that the body of the instrument is not subjected to violent shocks and vibrations.

When instruments are transported during hot or cold seasons, it is important to note the temperature range restrictions. After long distance transport, the instrument needs to be checked and calibrated according to the operating instructions before the instrument can be used.

#### Battery Transport

National and international regulations and guidelines must be followed when transporting batteries. Or contact your local shipping company for related information before shipping.

### 15.3. Cleaning and Drying

#### **Surface of Objective and Eyepiece**

- Do not touch the optical surfaces with your hands or other hard objects at any time.
- Blow the dust off the lens and prisms before cleaning.
- For cleaning use only a clean soft lens wiping cloth, lens paper, cotton swabs etc. If necessary, use pure water or pure alcohol to moisten them.

Do not use other liquids as they may damage the instrument parts.

#### **Fogging of Glass Surface**

If the temperature of the lens is lower than the ambient temperature, then it will tend to fog up. Generally, do not wipe, it can be left for a period of time, so that it slowly adapts to the surrounding temperature, the fog will generally disappear on its own.

#### **Drying the Instrument**

If the instrument or accessory has been slightly exposed to moisture or water, it can be left in a dry environment at a temperature not exceeding 40 °C for a period of time. After complete drying, the surface should be cleaned.

Always place the instrument in its case and close the cover when not in use in the field.

#### **Cables, Plugs and Charger**

Keep clean and dry at all times. When not in use, can wipe with a clean, dry cloth.

Do not use water or wiping tools with water to clean electrical accessories.



## 16. Appendix

### 16.1. Atmospheric Correction

The distance results measured by the instrument are correct only when corrected by the atmospheric correction value of ppm (mm/km,  $10^{-6}$ ). This scale correction value is calculated from the local meteorological parameters entered at the time of measurement. The atmospheric correction is related to factors such as atmospheric pressure and temperature.

For high precision distance measurements, the atmospheric correction must be accurate to 1ppm, the relevant meteorological parameters must be re-determined at the time of the distance measurement. The air temperature must be accurate to 1°C and the atmospheric pressure to 3hPa. The prevailing atmospheric parameters are entered into the instrument and the atmospheric correction for the distance measurement is automatically calculated.

#### The instrument default parameters:

Air temperature **20 °C**  
 Atmospheric pressure **1013.25 hPa**  
 Atmospheric correction **0 ppm**

#### Atmospheric correction formula:

$$\mathbf{kPT} = 279.097 - 0.29528 \times \mathbf{P} / (1 + 0.0036 \times \mathbf{T})$$

**kPT**: atmospheric correction (ppm)

**P**: pressure (hPa)

**T**: temperature (°C)

$$\mathbf{SD} = \mathbf{SD}_0 \times (1 + \mathbf{kPT})$$

**SD<sub>0</sub>**: original slope distance

**SD**: corrected slope distance

Atmospheric correction values can be conveniently found on the atmospheric correction chart below. The temperature is read on the horizontal axis of the chart and the pressure on the vertical axis, the value on the diagonal of its intersection is the atmospheric correction value.

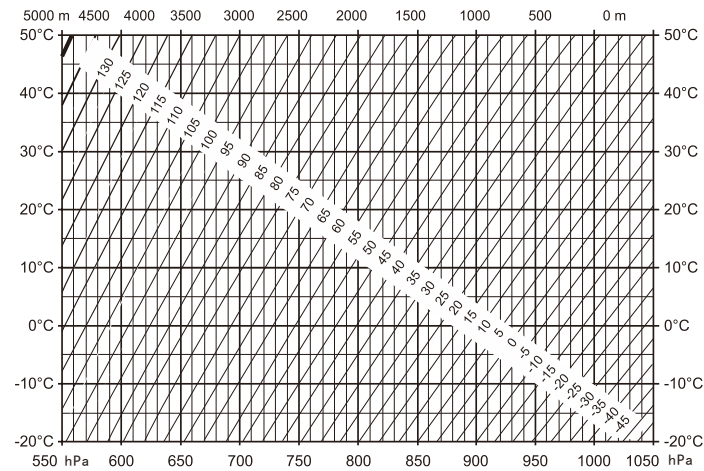

**For Example:**

The air temperature is **+15 °C**

The atmospheric pressure is **1013 hPa**

From the chart, the atmospheric correction is about **-5 ppm**

## 16.2. Refraction and Earth Curvature Correction

Considering the correction of refraction and earth curvature for distance measurement, the formula for SD, HD and VD applied in the instrument are as followings:

$$\mathbf{HD} = \mathbf{Y} - \mathbf{A} \times \mathbf{X} \times \mathbf{Y}$$

$$\mathbf{VD} = \mathbf{X} + \mathbf{B} \times \mathbf{Y}^2$$

**HD:** corrected horizontal distance

**VD:** corrected vertical distance

$$\mathbf{Y} = \mathbf{SD} \times |\sin \xi|$$

$$\mathbf{X} = \mathbf{SD} \times \cos \xi$$

**SD:** corrected slope distance

$\xi$ : the **ZA** (zenith 0)

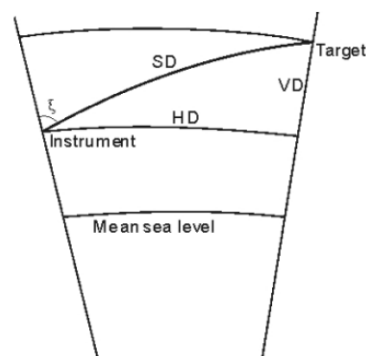

$$\mathbf{A} = (1 - \mathbf{k} / 2) / \mathbf{R}$$

$$\mathbf{B} = (1 - \mathbf{k} / 2) / 2\mathbf{R}$$

**k:** atmospheric refractive index, default **0.13**

**R:** average radius of the earth  **$6.37 \times 10^6$  m**

## Limited warranty standard

### General warranty for instruments.

The terms and conditions of this Limited Warranty constitute the complete and exclusive warranty agreement between The Customer or Dealer and STONEX® for the Product and it supersedes any prior agreement or representation made in any STONEX® sales document or advice that may be provided to Customer by any STONEX® representative in connection with Customer's purchase of the Product. No change to the conditions of this Limited Warranty is valid unless it is made in written form and signed by an authorized STONEX® supervisor. STONEX® warrants that:

1. Products are free from defects in materials or workmanship for generally 1/2 year except for accessories or specific parts for which different limited warranty period shall apply.
2. Products have been tested/calibrated in proper working status prior to shipment.

The warranty period starts from date of first sale of the instruments. At its sole discretion, under the warranty period, STONEX® will repair the product or send parts for replacement at its expense. STONEX® agree to repair or replace the defected instrument within thirty (30) days, only if STONEX® recognizes that the defects of the instrument are not caused by human factors or no obvious damage to its surface is visible. STONEX® warrants any new replaced parts or products are warranted to be free from defects in materials and workmanship for thirty (30) days or for the remainder of the Limited Warranty Period of the Product in which they are installed, whichever is longer. Faulty Parts or Products replaced under this Limited Warranty shall become property of STONEX®.

All products that have to be repaired have to be returned to our technical representative office location via any delivery company the customer prefers.

**NOTE:** STONEX® is not accountable for the unlikely event that the Products gets lost in transit.

Any damage inflicted by the customer or by third party after the products has been delivered to the customer is excluded from the limited warranty as well any damage arising from an improper use, from any action or use not provided for in the enclosed user guides and/or manuals.

### Shipping policy

The Customer or the dealer is required to pay for the charges for shipping of fault parts or instruments to STONEX® representative office and STONEX® (will provide) the shipping for return. Dealers needs to follow STONEX® repair/service procedure to achieve a better and prompt service result.

### Return policy dead on arrival instruments

All returned products have to be shipped to STONEX® representative office.

The original Purchaser has a period of seven (7) days, starting from date (data) of purchasing to signal the existence of a defect in the instrument for a full refund (less shipping and handling), provided the merchandise is in new, resalable condition and returned in the original, undamaged packaging. Customer has to pay for both the return and the original freight fees, regardless of the original freight paid by the Company. All warranty books, instruction manuals, parts and accessories must be included as well as the original box in which the item was shipped. We recommend placing the original carton inside another box, to avoid any additional damage to the carton itself. In some cases, returns of special items will require a re-stock fee. Acceptance of returned merchandise is final only

after inspection by STONEX®.

Above terms and (policy shall apply as for hardware.) Dealers needs to follow STONEX® repair/service procedure to achieve a better and prompt service result.

### Firmware/Software warranty.

Stonex doesn't warrant that operation of Firmware/Software on any instruments will be uninterrupted or error-free, or that functions contained in Firmware/Software will operate to meet your requirements.

Stonex will forward the Software/Firmware Fix to the dealer or customer. Firmware/software Fix means an error correction or other update created to fix a previous firmware version that substantially doesn't conform to the instrument's specification.

### Over warranty repair(s) policy.

Customer shall pay the standard repair fees for any service (whether part replacement or repairs) and performed by STONEX® under request and explicit authorization of the customer itself. In this case the customer is charged for return shipment's fees as well.

### Disclaimer and limitation of remedy.

All other express and implied warranties for this product, including the implied warranties of merchantability and fitness for a particular purpose and/or noninfringement of any third party's rights, are hereby disclaimed. Stonex® expressly disclaims all warranties not stated in this limited warranty. Any implied warranties that may be imposed by law are limited in duration to the term of this limited warranty. Some jurisdictions do not allow the exclusion of implied warranties or limitations on how long an implied warranty lasts, so the above exclusions or limitations may not apply to customer. Customer must read and follow all set-up and usage instructions in the applicable user guides and/or manuals enclosed. If customer fails to do so, this product may not function properly, and may be damaged. Customer may lose data or sustain personal injuries. Stonex®, its affiliates and suppliers do not warrant that operation of this product will be uninterrupted or error free; as do all electronics at times. If this product fails to work as warranted above, customer's sole and exclusive remedy shall be repair or replacement. In no event will STONEX®, its affiliates or suppliers be liable to customer or any third party for any damage in excess of the purchase price of the product. This limitation applies to damages of any kind whatsoever including (1) damage to, or loss or corruption of, customer's records, programs, data or removable storage media, or (2) any direct or indirect damages, lost profits, lost savings or other special, incidental, exemplary or consequential damages, whether for breach of warranty, contract, tort or otherwise, or whether arising out of the use of or inability to use the product and/or the enclosed user guides and/or manuals, even if STONEX®, or an authorized STONEX® representative, authorized service provider or reseller has been advised of the possibility of such damages or of any claim by any other party. Some jurisdictions do not allow the exclusion or limitation of incidental or consequential damages for some products, so the exclusions or limitations may not apply to customer. This limited warranty gives customer specific legal rights, and customer may also have other rights which vary from country/state/jurisdiction to country/state/.

### Instrument warranty

Two years on Total Station R25 excluding battery and power supply accessories (6 months).

## Environmental recycling

- The cardboard box, the plastic in the package and the various parts of this product have to be recycled and disposed of in accordance with the current legislation of your Country.
- **FOR COUNTRIES IN THE EUROPEAN UNION (EU)**
- The disposal of electric and electronic device as solid urban waste is strictly prohibited: they must be collected separately.
- Contact Local Authorities to obtain practical information about correct handling of the waste, location and times of waste collection centers. When you buy a new device of ours, you can give back to our dealer a used similar device.
- The dumping of these devices at unequipped or unauthorized places may have hazardous effects on health and environment.
- The crossed dustbin symbol means that the device must be taken to authorized collection centers and must be handled separately from solid urban waste.



- **FOR COUNTRIES OUTSIDE EUROPEAN UNION (EU)**

The treatment, recycling, collection and disposal of electric and electronic devices may vary in accordance with the laws in force in the Country in question.



STONEX® SRL

Viale dell'industria, 53 | 20037 - Paderno Dugnano (MI) | Italy

Tel : + 390278619201 | Fax :+ 390278610299

[www.stonex.com](http://www.stonex.com) | [info@stonex.com](mailto:info@stonex.com)